



LXI Example and Reference Material

Revision 1.1

10 July 2017

LXI EXAMPLE AND REFERENCE MATERIAL	1
<i>REFERENCE DOCUMENTS</i>	3
<i>REVISION HISTORY</i>.....	5
1 OVERVIEW	6
2 LAN STATUS INDICATION	7
3 LAN CONFIGURATION INITIALIZE (LCI).....	9
4 EXAMPLE WEB PAGES.....	10
LXI INSTRUMENT WELCOME PAGE.....	11
LXI LAN CONFIGURATION PAGE	12
LXI ADVANCED IP CONFIGURATION PAGE.....	14
LXI LAN EVENTS PAGE	15
LXI EVENT LOGGING CONTROL PAGE.....	17
LXI SECURITY CONFIGURATION PAGE.....	18
5 LXI EVENT PACKET EXAMPLES.....	19
6 EXAMPLE XML IDENTIFICATION CONTENT	21
7 LXI DISCOVERY USING MDNS.....	24
8 GLOSSARY OF TERMS	26

Reference Documents

Notice of Rights All rights reserved. This document is the property of the LXI Consortium. It may be reproduced, unaltered, in whole or in part, provided the LXI copyright notice is retained on every document page.

Notice of Liability The information contained in this document is subject to change without notice. “Preliminary” releases are for specification development and proof-of-concept testing and may not reflect the final “Released” specification.

The LXI Consortium, Inc. makes no warranty of any kind with regard to this material, including but not limited to, the implied warranties of merchantability and fitness for a particular purpose. The LXI Consortium, Inc. shall not be liable for errors or omissions contained herein or for incidental or consequential damages in connection with the furnishing, performance, or use of this material.

LXI Standards Documents are developed within the LXI Consortium and LXI Technical Working Groups sponsored by the LXI Consortium Board of Directors. The LXI Consortium develops its standards through a consensus development process modeled after the American National Standards Institute, which brings together volunteers representing varied viewpoints and interests to achieve the final product. Volunteers are not necessarily members of the Consortium and serve without compensation. While the LXI Consortium administers the process and establishes rules to promote fairness in the consensus development process, the LXI Consortium does not exhaustively evaluate, test, or verify the accuracy of any of the information contained in its standards.

Use of an LXI Consortium Standard is wholly voluntary. The LXI Consortium and its members disclaim liability for any personal injury, property or other damage, of any nature whatsoever, whether special, indirect, consequential, or compensatory, directly or indirectly resulting from the publication, use of, or reliance upon this, or any other LXI Consortium Standard document.

The LXI Consortium does not warrant or represent the accuracy or content of the material contained herein, and expressly disclaims any express or implied warranty, including any implied warranty of merchantability or fitness for a specific purpose, or that the use of the material contained herein is free from patent infringement. LXI Consortium Standards documents are supplied “as is”. The existence of an LXI Consortium Standard does not imply that there are no other ways to produce, test, measure, purchase, market, or provide other goods and services related to the scope of the LXI Consortium Standard. Furthermore, the viewpoint expressed at the time a standard is approved and issued is subject to change brought about through developments in the state of the art and comments received from users of the standard. Every LXI Consortium Standard is subjected to review at least every five years for revision or reaffirmation. When a document is more than five years old and has not been reaffirmed, it is reasonable to conclude that its contents, although still of some value, do not wholly reflect the present state of the art. Users are cautioned to check to determine that they have the latest edition of any LXI Consortium Standard.

In publishing and making this document available, the LXI Consortium is not suggesting or rendering professional or other services for, or on behalf of, any person or entity. Nor is the LXI Consortium undertaking to perform any duty owed by any other person or entity to another. Any person utilizing this, and any other LXI Consortium Standards document, should rely upon the advice of a competent professional in determining the exercise of reasonable care in any given circumstances.

This specification is the property of the LXI Consortium, a Delaware 501c3 corporation, for the use of its members.

Interpretations Occasionally questions may arise regarding the meaning of portions of standards as they relate to specific applications. When the need for interpretations is brought to the attention of LXI Consortium, the Consortium will initiate action to prepare appropriate responses. Since LXI Consortium Standards represent a consensus of concerned interests, it is important to ensure that any interpretation has

also received the concurrence of a balance of interests. For this reason, LXI Consortium and the members of its working groups are not able to provide an instant response to interpretation requests except in those cases where the matter has previously received formal consideration. Requests for interpretations of this standard must be sent to interpretations@lxistandard.org using the form “*Request for Interpretation of an LXI Standard Document*”. This document plus a list of interpretations to this standard are found on the LXI Consortium’s Web site: <http://www.lxistandard.org>

Trademarks Product and company names listed are trademarks or trade names of their respective companies. No investigation has been made of common-law trademark rights in any work.

LXI is a registered trademark of the LXI Consortium

Patents: Attention is drawn to the possibility that some of the elements of this document may be the subject of patent rights. A holder of such patent rights has filed a copy of the document “*Patent Statement and Licensing Declaration*” with the Consortium. By publication of this standard, no position is taken with respect to the existence or validity of any patent rights in connection therewith. Other patent rights may exist for which the LXI Consortium has not received a declaration in the form of the document “*Patent Statement and Licensing Declaration*”. The LXI Consortium shall not be held responsible for identifying any or all such patent rights, for conducting inquiries into the legal validity or scope of patent rights, or determining whether any licensing terms or conditions are reasonable or non-discriminatory. Users of this standard are expressly advised that determination of the validity of any patent rights, and the risk of infringement of such rights, is entirely their own responsibility.

Conformance The LXI Consortium draws attention to the document “*LXI Consortium Policy for Certifying Conformance to LXI Consortium Standards*”. This document specifies the procedures that must be followed to claim conformance with this standard.

Legal Issues Attention is drawn to the document “*LXI Consortium Trademark and Patent Policies*”. This document specifies the requirements that must be met in order to use registered trademarks of the LXI Consortium.

Revision history

<i>Revision</i>	<i>Description</i>
1.1 Version	Corrections to Web Pages, XML Identification, addition of mDNS, and other corrections.
1.0 Version	Initial Release November 8, 2016

1 Overview

This document contains a repository of examples and discussions to assist developers in achieving LXI conformance. This material is considered *Informative*, which means it contains information, terminology, example web pages, XML file content, etc. that is not subject to the strict revision and content control required for the LXI Device Specification or other LXI standard documents.

The glossary is considered *Normative*, based upon what is regarded as the standard of correctness in using the terminology. The terminology found in the glossary is used in Rules and Permissions in determining whether a device is conformant to the LXI Standard.

Additions and subtractions deemed useful by LXI members and committees need only approval by key member involvement and does not require overall LXI membership voting.

2 LAN Status Indication

The health status of LAN for an LXI Device is very important to Users. Section 2.5 of the LXI Device Specification illustrates various methods to display LAN Status. Rule 8.10 provides additional information related to indication of LAN Configuration problems. In general, the following bulleted items cover the common error concerns:

- Failure to acquire a valid IP address
- Detection of a duplicate IP address
- Failure to renew an already acquired DHCP lease
- LAN cable disconnected

There are roughly three types of front panel interfaces found on most LXI devices:

- Front Panel with high resolution graphical display
- Front Panel with no display and using LEDs to convey information
- Front Panel with limited display showing only alpha-numeric characters

Each of these are illustrated in the figure below.

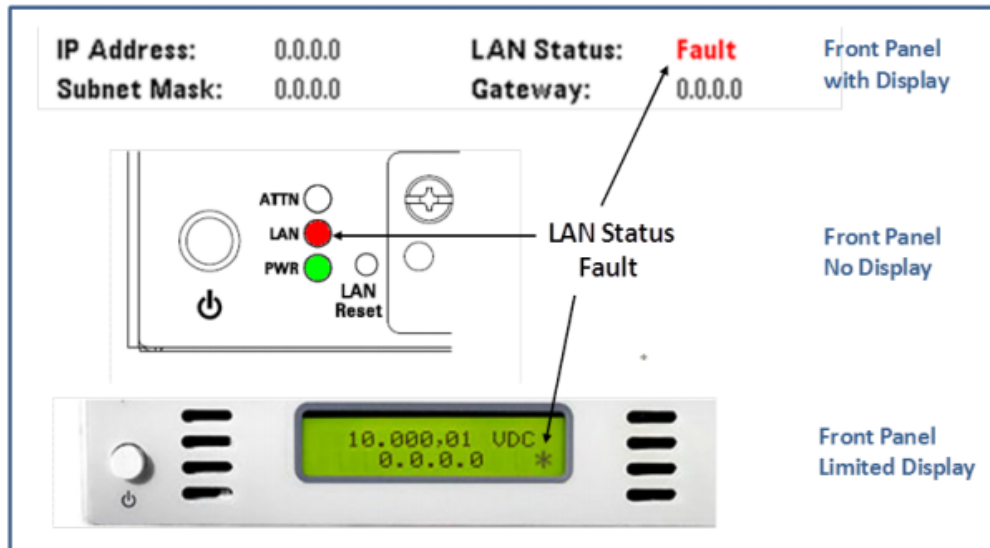

The first two examples have clear indications on the Front Panel that something is wrong with the LAN connection. The LAN Status Fault condition is presented as a Red LED or IP address of all zeros. LXI Devices with Front Panel Displays using high-resolution graphics often implement the LAN Status information deep within menus. Once found, those displays must contain a LAN Status that indicates the health of the LAN. In the case above, Red letters indicating a **Fault** draw the User's attention to a problem.

It is not sufficient to supply only an IP address with 0.0.0.0 as an indication of fault condition. Such is the case with the bottom device using a limited display. Note the use of 0.0.0.0 as an indication of fault, but also note the inclusion of the "*" character. This additional character signals an error condition.

In all cases above, the User of the device refers to documentation to determine the problem. User documentation would then signal what the various fault conditions indicate. For example, the LXI Device Specification specifies a solid vs. blinking LED or different colors with different meanings.

When supplying a high-resolution display where the LAN Status information is implemented deep in the menu structure, you should consider providing some sort of LAN Status on the main display. Some vendors use methods similar to what you might find in the lower right corner on a computer display, where a small icon representing the LAN network health shows some of the following indicators:

- Red slash through a circle over LAN icon
- Yellow yield sign near LAN icon
- Revolving ball over LAN icon
- Flashing pattern indicating LAN reconnecting

LXI Devices with menu driven displays often make use of Information Dialogs that pop up on top of the display to indicate issues such as Lost Connection, Lost Lease, or Duplicate IP address. This signals the User to address the problem and is important for such problems.

3 LAN Configuration Initialize (LCI)

Section 2.4.5 refers to Rules associated with LCI or LAN Reset. This is a very important part of an LXI Device. For devices without menu-driven Front Panel displays, a button accessible from a recessed hole on the front or back of the device is required. For devices with menu-driven displays, the LCI is often found implemented deep within the menu structure under various headings:

- System or System Configuration
- Utility or Utilities
- IO Configuration

In all cases, the LXI standard requires a protection mechanism to avoid accidentally pressing the LCI function. In the case of limited or no displays, the recessed button provides this safety. For menu-driven displays, a simple warning pop-up dialog, to indicate the operation, provides such a safety mechanism.

Finding the LCI mechanism should be of primary importance when planning your front panel. Equipment shared by multiple users might acquire any of the following, which make the product virtually useless to the next User if not known or controllable:

- User password set to lock out LAN configuration or control
- LXI Device set to Manual IP address on unknown subnet
- Various discovery protocols disabled (e.g. mDNS)

The User need only press the LCI mechanism from the Front Panel to clear up these issues. The LXI password is cleared, IP Autoconfiguration (DHCP) is restored, and mDNS and other discovery protocols are re-activated. Section 8.13 of the LXI Device Specification supplies a table of the items affected by LCI along with the associated sections.

When using static IP addressing, it is very easy to pick an address already in use by another device. The LXI device must withdraw its LAN connection or drop into AutoIP (Link Local Addressing) to remain connected. LCI can restore the LXI Device to a connected LAN status.

4 Example Web Pages

The following sample web pages are for reference in constructing pages that adhere to the requirements of the LXI Specification. The example pages show both blank examples and typical content. These example pages derive from the [LXI Reference Design](#), as indicated in the upper right of each page.

Section 9.10 refers to this document when planning your web pages. You need not follow the *exact* format, colors, or layout shown in the example pages. Your final web pages should contain the **required content**, as indicated in the various headings on each of the example web pages. You may follow your company's guidelines for format, colors, or layout.

For example, here are a couple of Vendor Welcome Pages using Vendor colors, layout, etc.

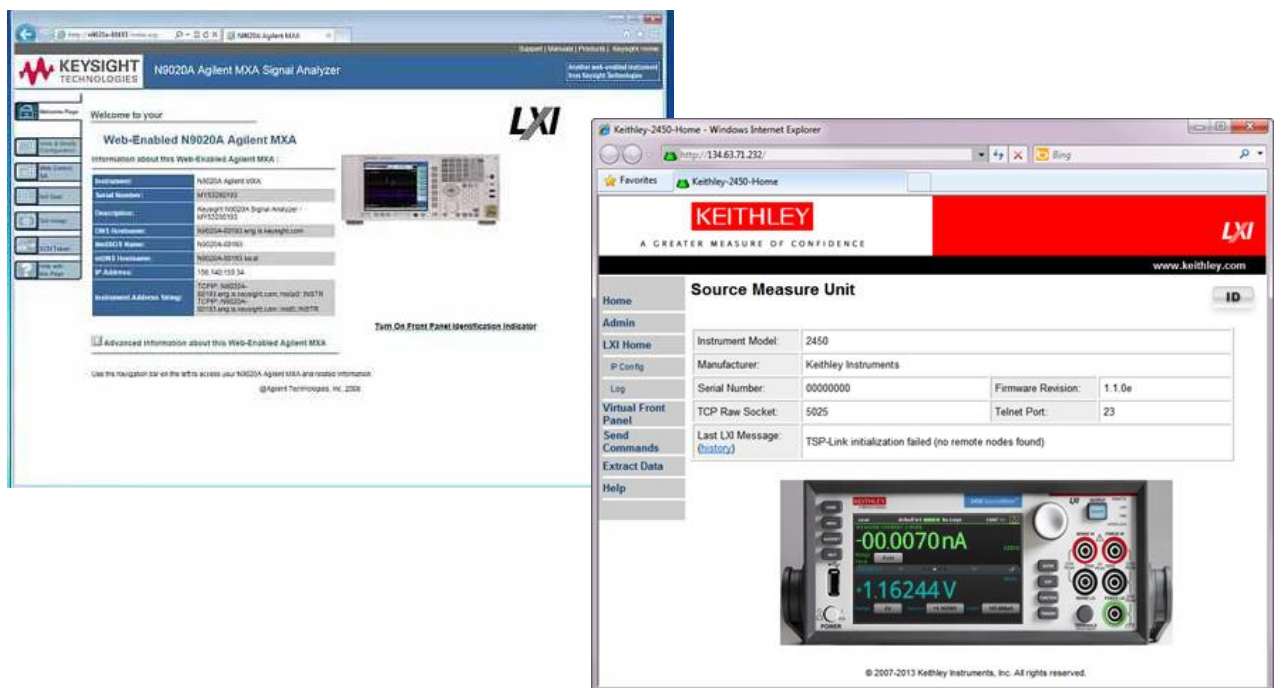

The LXI Device Specification and the various LXI Extended Function documents detail the content required for these pages.

LXI Instrument Welcome Page

The Welcome Page of the LXI Device is accessed by entering the IP Address or Hostname into an Internet Browser. Section 9.2 in the LXI Device Specification addresses the required content. Notice the links on the left in the image below. Those links point to additional pages of which some are required for all LXI Devices. For example, all LXI Devices must provide a LAN Configuration and Security page. Others, such as Logging and LAN Events in this example, are required when implementing various LXI Extended Functions.

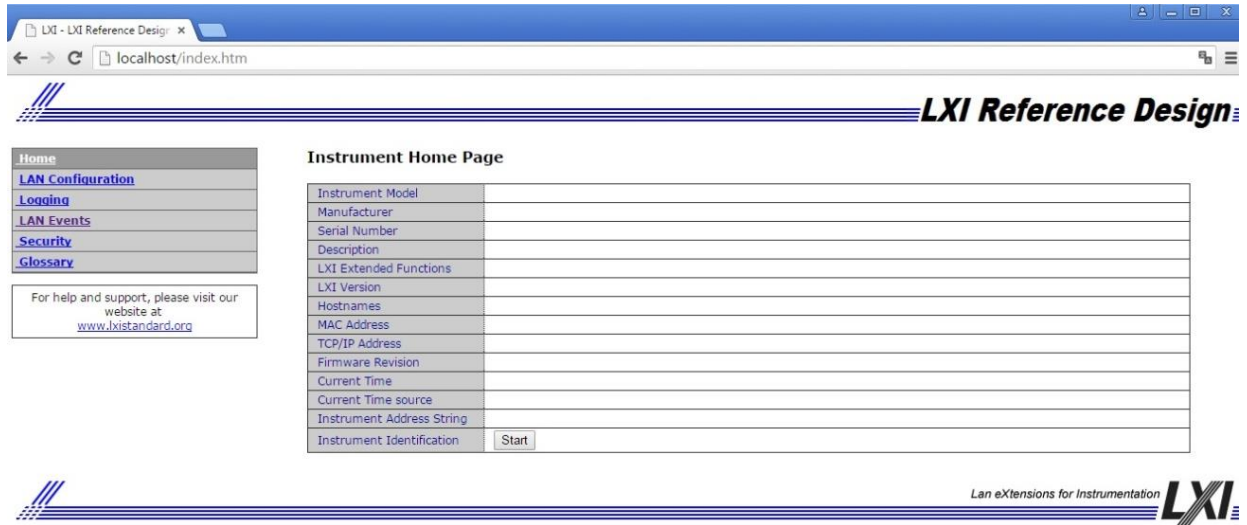

Blank LXI Welcome Page

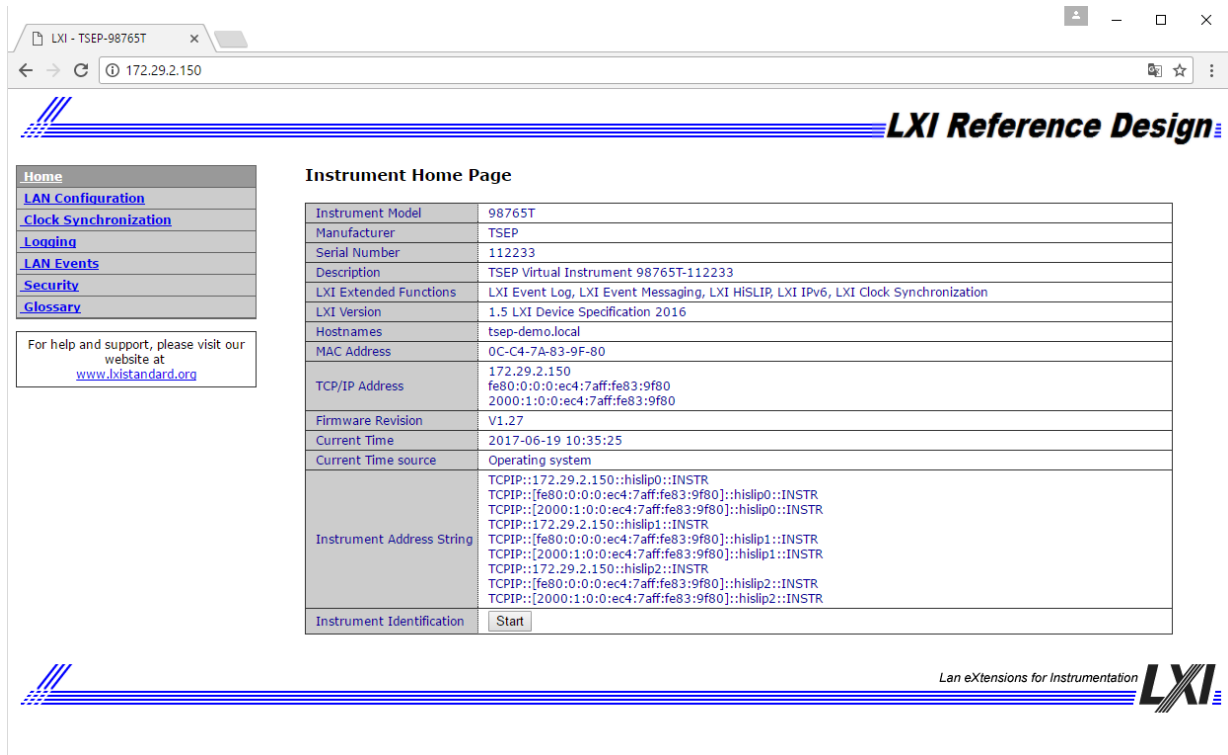

Example LXI Welcome Page

LXI LAN Configuration Page

The following show examples of LAN Configuration for both IPv4 and IPv6. Section 9.5 of the LXI Device Specification addresses the content for IPv4. Section 21.11 of the LXI Extended Function IPv6 addresses its content requirements.

The screenshot shows the 'IPv4 Configuration' page in a web browser. The browser address bar shows 'localhost/ipconfig.htm'. The page has a blue header with the LXI Reference Design logo. On the left, there is a navigation menu with links for Home, LAN Configuration, Logging, LAN Events, Security, and Glossary. Below the menu is a support link: 'For help and support, please visit our website at www.lxistandard.org'. The main content area is titled 'IPv4 Configuration' and contains several form fields: Hostname, DNS Hostname(s), Domain Name, HISLIP Port, and Description. Below these is a 'Submit' button. Further down, there is a 'TCP/IP Mode' section with radio buttons for 'DHCP & Auto-IP' (selected) and 'Manual'. A note below reads: 'IP configuration sequence, at least one configuration must be selected'. Below this is an 'Adapter name' field and a table for IP configuration parameters: IP Address, Subnet Mask, Default Gateway, and DNS Server(s). Each parameter is represented by a row of input boxes. A 'Submit' button is located below the table. At the bottom, there is a link '> Advanced IP Configuration' and the LXI logo with the text 'Lan eXtensions for Instrumentation'.

The screenshot shows the 'IPv6 Configuration' page in a web browser. The browser address bar shows 'localhost/ipv6config.htm'. The page has a blue header with the LXI Reference Design logo. On the left, there is a navigation menu with links for Home, LAN Configuration, Logging, LAN Events, Security, and Glossary. Below the menu is a support link: 'For help and support, please visit our website at www.lxistandard.org'. The main content area is titled 'IPv6 Configuration' and contains several form fields: Hostname, DNS Hostname(s), Domain Name, HISLIP Port, and Description. Below these is a 'Submit' button. Further down, there is a 'TCP/IP Mode' section with radio buttons for 'DHCP/Auto-IP' and 'SLAAC/Auto-IP'. A note below reads: 'IP configuration sequence, at least one configuration must be selected'. Below this is an 'Adapter name' field and a table for IPv6 configuration parameters: Link-Local IP Address, IP Address, Subnet Prefix Length, Default Gateway, and DNS Server(s). Each parameter is represented by a row of input boxes. A 'Submit' button is located below the table. At the bottom, there is a link '> Advanced IP Configuration' and the LXI logo with the text 'Lan eXtensions for Instrumentation'.

Blank IPv4 and IPv6 LAN Configuration Pages



- Home
- [LAN Configuration](#)
- [IPv4 Configuration](#)
- [IPv6 Configuration](#)
- [Clock Synchronization](#)
- [Logging](#)
- [LAN Events](#)
- [Security](#)
- [Glossary](#)

For help and support, please visit our website at www.lxistandard.org

IPv4 Configuration

Hostname	tsep-demo
DNS Hostname(s)	tsep-demo.local
Domain Name	
HISLIP Port	4880
Description	TSEP Virtual Instrument 98765T-112233

Submit

TCP/IP Mode	<input checked="" type="checkbox"/> DHCP & Auto-IP	-->	<input type="checkbox"/> Manual
IP configuration sequence, at least one configuration must be selected			

Adapter name	eno1
IP Address	172 . 29 . 2 . 150
Subnet Mask	255 . 255 . 0 . 0
Default Gateway	172 . 29 . 2 . 1
DNS Server(s)	172 . 29 . 2 . 1 192 . 168 . 1 . 7

Submit

[» Advanced IP Configuration](#)



- Home
- [LAN Configuration](#)
- [IPv4 Configuration](#)
- [IPv6 Configuration](#)
- [Clock Synchronization](#)
- [Logging](#)
- [LAN Events](#)
- [Security](#)
- [Glossary](#)

For help and support, please visit our website at www.lxistandard.org

IPv6 Configuration

Hostname	tsep-demo
DNS Hostname(s)	tsep-demo.local
Domain Name	
HISLIP Port	4880
Description	TSEP Virtual Instrument 98765T-112233

Submit

TCP/IP Mode	<input type="checkbox"/> DHCP/Auto-IP	-->	<input checked="" type="checkbox"/> SLAAC/Auto-IP
IP configuration sequence, at least one configuration must be selected			

Adapter name	eno1
Link-Local IP Address	fe80 : 0 : 0 : 0 : ec4 : 7aff : fe83 : 9f80
IP Address	2000 : 1 : 0 : 0 : ec4 : 7aff : fe83 : 9f80
Subnet Prefix Length	64
Default Gateway	fe80 : 0 : 0 : 0 : 2a0 : 57ff : fe16 : c9a5
DNS Server(s)	

[» Advanced IP Configuration](#)

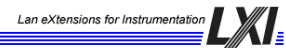

Example IPv4 and IPv6 LAN Configuration Pages

LXI Advanced IP Configuration Page

Some LAN Configurations are optional, as indicated in the LXI Device Specification. Here is an example of implementing some of those features. Some vendors actually place such features illustrated below within the LAN Configuration page, as described earlier.

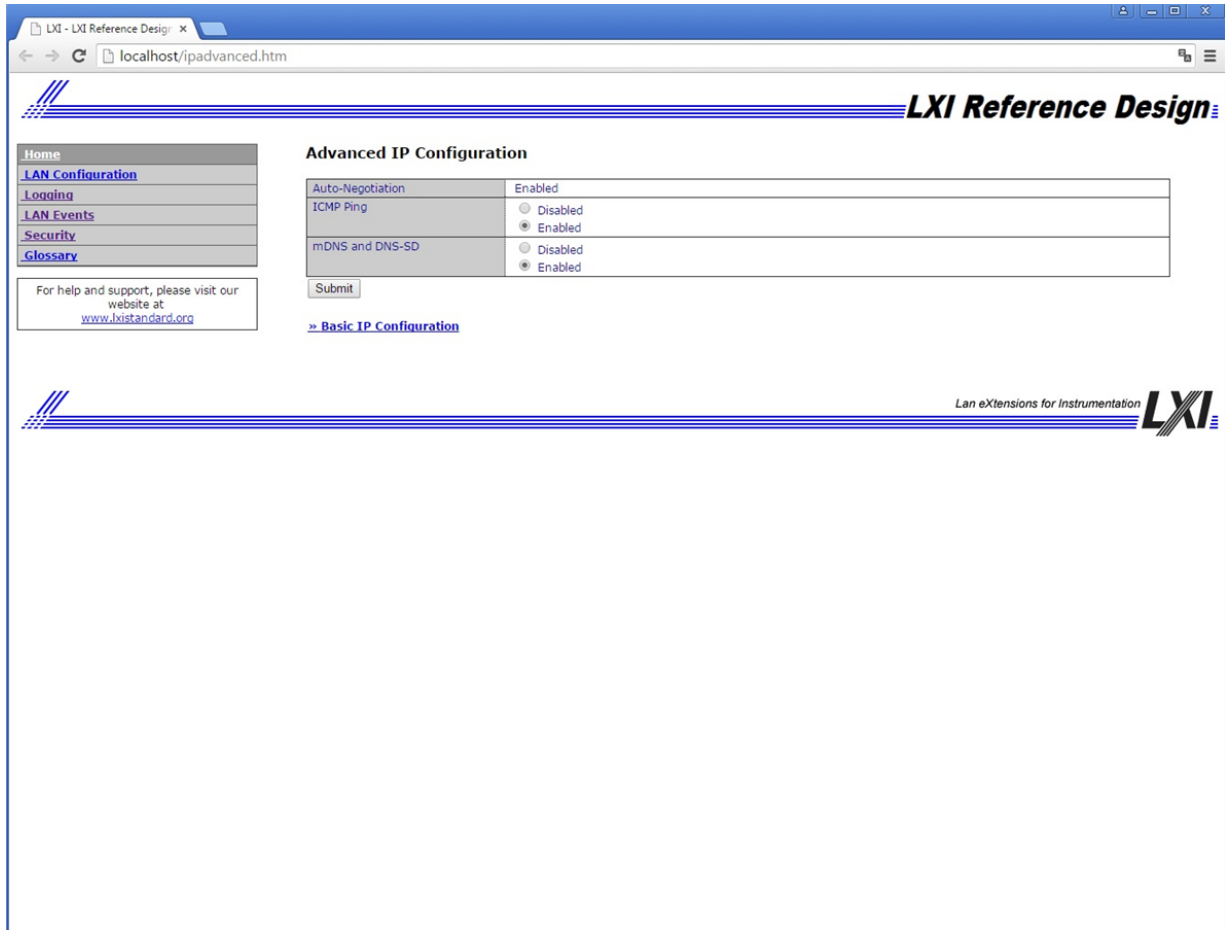

LXI LAN Events Page

Section 4.3 of the LXI Event Messaging Extended Function addresses the content of the LAN Events page.

LAN Event Parameter

Own Domain:

Manual LAN Events

Event ID: LAN 0

Flags

- Error Message
- Acknowledgement
- Stateless Event
- HW Flag

Use Timestamp (Out of scope) (Disabled)

UDP multicasting TCP

Send to IPv4: . . . If IPv4 is incomplete or exceeds the range of 0 to 255, IPv6 is submitted.

Send to IPv6: : : : : : : :

Submit Event

LAN Events History

	Recv.From	Proto	Domain	Event Id	Sequence	IEEE Ts	IEEE Ep	Err	ReT	HW
Current Processed LAN Events: (max. 8 events)										

Clear History Refresh History

Lan eXtensions for Instrumentation LXI

Blank LAN Events Page

http://localhost/lanevents.htm LXI - TSEP-98765T

LXI Reference Design

Home

[LAN Configuration](#)

[Logging](#)

[LAN Events](#)

[Security](#)

[Glossary](#)

For help and support, please visit our website at www.lxistandard.org

LAN Event Parameter

Own Domain:

Manual LAN Events

Event ID	<input type="text" value="LAN 0"/>		
Flags	<input type="checkbox"/> Error Message <input type="checkbox"/> Acknowledgement <input type="checkbox"/> Stateless Event <input type="checkbox"/> HW Flag		
Use Timestamp (Out of scope)	<input type="checkbox"/> (Disabled)		
UDP multicasting TCP	<input checked="" type="radio"/> <input type="radio"/>		
Send to IPv4:	<input type="text"/> . <input type="text"/> . <input type="text"/> . <input type="text"/> <small>If IPv4 is incomplete or exceeds the range of 0 to 255, IPv6 is submitted.</small>		
Send to IPv6:	<input type="text"/> : <input type="text"/> : <input type="text"/> : <input type="text"/> : <input type="text"/> : <input type="text"/> : <input type="text"/> : <input type="text"/>		

LAN Events History

	Recv.From	Proto	Domain	Event Id	Sequence	IEEE Ts	IEEE Ep	Err	ReT	HW
Current Processed LAN Events:	fe80:0:0:0:cb5:55fa:3f0a:c7c4	UDP	0	LAN0	1	not used	0	false	false	false
(max. 8 events)	192.168.7.120	UDP	0	LAN0	1	not used	0	false	false	false
	192.168.7.120	UDP	0	LAN0	2	not used	0	false	false	false
	fe80:0:0:0:cb5:55fa:3f0a:c7c4	UDP	0	LAN0	2	not used	0	false	false	false

Lan eXtensions for Instrumentation **LXI**

Example LAN Events Page

LXI Event Logging Control Page

Section 4.3 of the LXI Event Messaging Extended Function addresses the content of the LXI Events page. Here is an example from the LXI Reference Design. Section 6 of the LXI Event Log Extended Function has additional information of Event Logging and formats.

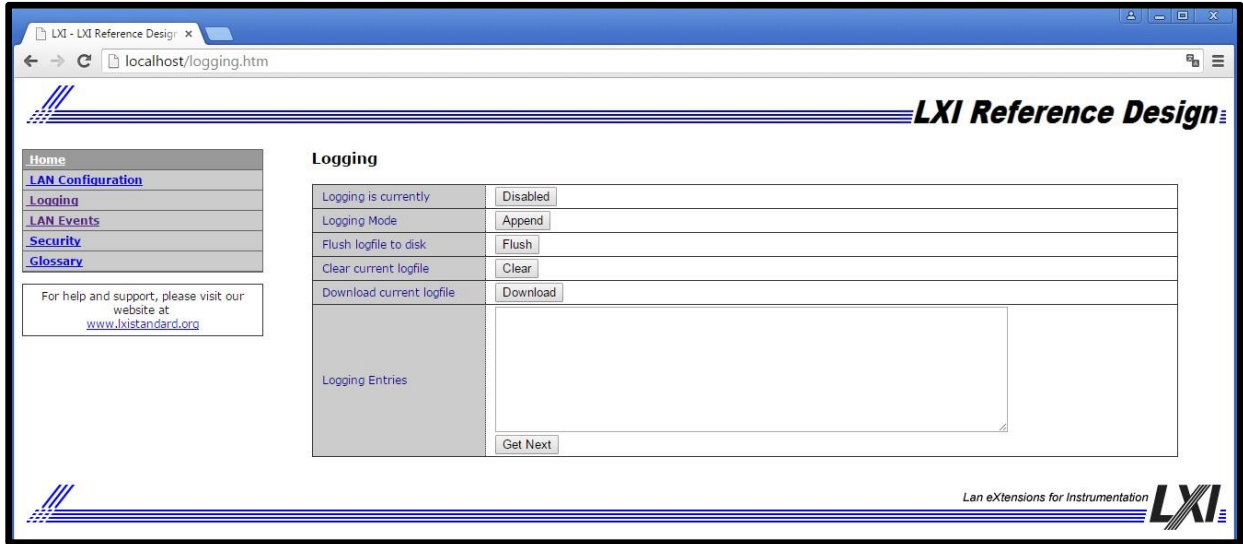

Blank LXI Event Logging Page

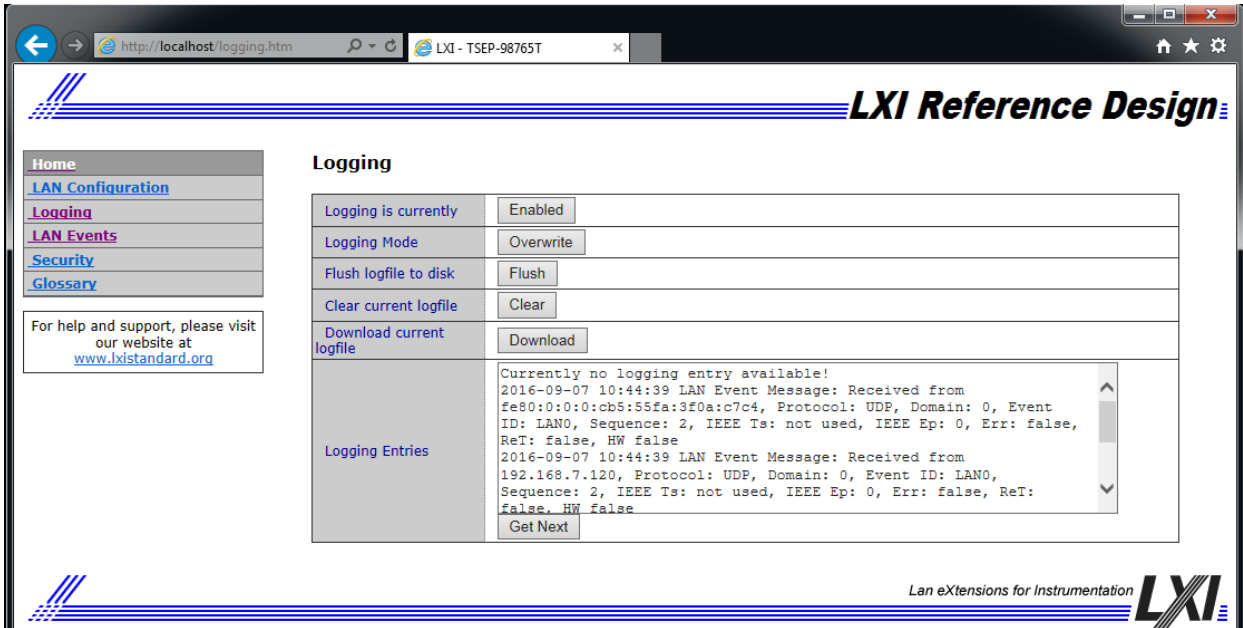

Example LXI Event Logging Page

LXI Security Configuration Page

Section 9.8 of the LXI Device Specification addresses Web Page Security. LAN Security need not have its own page, as some vendors add this to the LAN Configuration page. Here is an example of securing the configuration or Web-control pages of your LXI Device.

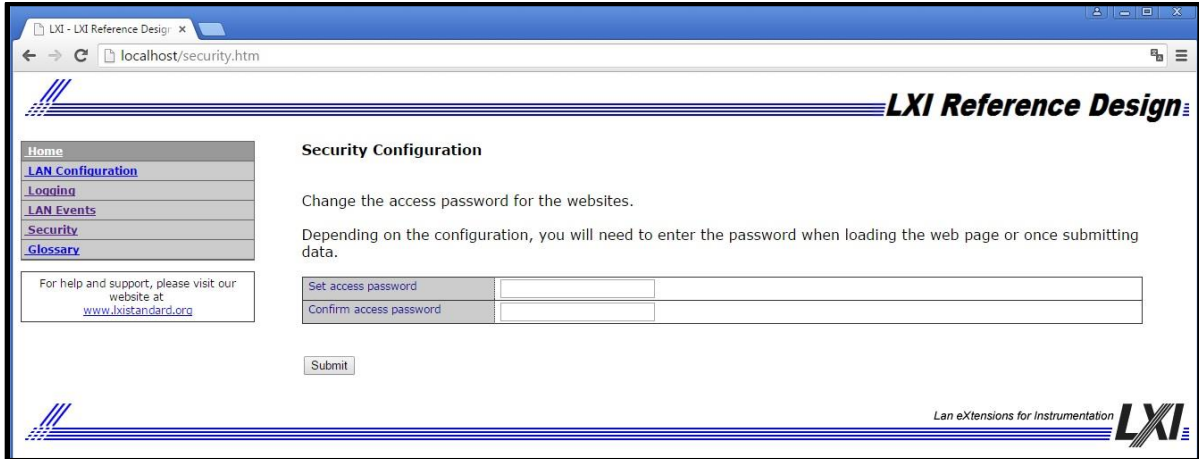

5 LXI Event Packet Examples

Section 4.3 of the LXI Event Messaging Extended Function addresses the format of the LXI Events page

Table 5.1 gives several examples of LXI Event packets.

Note: The packet is terminated by a data length field with a value of zero (0x0000).

Note: All multi-octet fields are transmitted as big-endian.

Table 5.1 – LXI Event Packet Examples

Packet Header (ASCII)	Domain	Identifier	Sequence Number	Seconds	Nanoseconds	Fractional Nanoseconds	Epoch	Flags 0: Error 1: 2:Signal Value 3: Ack
3 Octets	1 Octet (uint8)	16 Octets null padded	4 Octets (uint32)	4 Octets (uint32)	4 Octets (uint32)	2 Octets (uint16)	2 Octets (uint16)	2 Octets (uint16)
LXI	0x00	LAN0	0x1357feff	0x00000002	0x00000111	0x0000	0x0000	0x0004 HDWR Value = TRUE
LXI	0x00	LAN5	0x12345678	0x00000002	0x80000000	0x0000	0x0000	0x0004 HDWR Value = TRUE
LXI	0x01	LAN3	0xff000539	0x463682c3	0x1dcd6500	0x0000	0x0000	0x0008 ACK & HDWR Value = FALSE

Table 5.2 illustrates usage of the data fields.

Note: All LXI Event packets must be terminated by an empty data field – that is, one with a Data Length field with a value of zero and no Identifier or User Data field.

Table 5.2 – Usage

Data Length (2 octets)	Identifier (1 octet)	User Data (Data Length octets; encoded in hexadecimal)	Notes
0x0008	0x04	0102 0304 0506 0708	User-defined data type
0x0011	0xFF	5468 6973 2069 7320 6120 7374 7269 6E67 2E	The ASCII string, “This is a string.”
0x0008	0xFC	0102 1112 2122 3132	Four int16’s
0x0000			Packet Terminator

The octet stream for the LXI Event in the first row of Table 5.1 containing all of the data fields of Table 5.2 and encoded in hexadecimal would be the following:

```
4C58 4900 4C41 4E30 0000 0000 0000 0000 0000 0000 1357 FFFF 0000 0002
0000 0111 0000 0000 0004 0008 0401 0203 0405 0607 0800 11FF 5468 6973
2069 7320 6120 7374 7269 6E67 2E00 08FC 0102 1112 2122 3132 0000
```

Octets	Notes
4C58 49 00 4C41 4E30 0000 0000 0000 0000 0000 0000 1357 FFFF 0000 0002 0000 0111 0000 0000 0004 0008 04 0102 0304 0506 0708 0011 FF 5468 6973 2069 7320 6120 7374 7269 6E67 2E 0008 FC 0102 1112 2122 3132 0000	LXI Domain = 0 Event ID = “LAN0” Sequence Number Seconds Nanoseconds Fractional Nanoseconds Epoch Flags (Hardware Value = True) Data Length = 8 Identifier (user-defined) User Data Data Length = 17 Identifier (0xFF – String) User Data (“This is a string.”) Data Length = 8 Identifier (0xFC – int16) User Data Data Length = 00 / Packet Terminator

6 Example XML Identification Content

Section 10 of the LXI Device Specification covers LAN Discovery and Identification. Section 10.2, in particular, covers the XML Identification Document. This document is auto-generated by the LXI Device as LAN configuration changes. It is located at <IP Address>/lxi/identification of the LXI Device.

The following XML files are example instances of the LXI Identification and its extension (available at <http://www.lxistandard.org/InstrumentIdentification/1.0>).

Identification Document

Example Identification Document conforming to LXI InstrumentIdentification that illustrates ConnectedDevices, use of the Extension element for vendor-specific data, and the schema location attribute:

```
<?xml version="1.0" encoding="UTF-8" ?>
<LXIDevice xmlns="http://www.lxistandard.org/InstrumentIdentification/1.0"
  xmlns:xsi="http://www.w3.org/2001/XMLSchema-instance"
  xsi:schemaLocation="http://www.lxistandard.org/InstrumentIdentification/1.0
    LXIIdentification.xsd">
  <Manufacturer>My Company, Inc.</Manufacturer>
  <Model>EX1234</Model>
  <SerialNumber>543210</SerialNumber>
  <FirmwareRevision>1.2.3a</FirmwareRevision>
  <ManufacturerDescription>Sample Device</ManufacturerDescription>
  <HomepageURL>http://www.mycompany.com</HomepageURL>
  <DriverURL>http://www.mycompany.com</DriverURL>
  <ConnectedDevices>
    <DeviceURI>http://sampledevice.local/devices/device0/</DeviceURI>
    <DeviceURI>http://sampledevice.local/devices/device2/</DeviceURI>
  </ConnectedDevices>
  <UserDescription>Demo of Identification Schema</UserDescription>
  <IdentificationURL>http://sampledevice.local/lxi/identification</IdentificationURL>
  <Interface xsi:type="NetworkInformation" InterfaceType="LXI" IPType="IPv4"
    InterfaceName="eth0">
    <InstrumentAddressString>TCPIP::10.1.2.32::INSTR</InstrumentAddressString>
    <InstrumentAddressString>TCPIP::10.1.2.32::5000::SOCKET</InstrumentAddressString>
    <InstrumentAddressString>TCPIP::10.1.2.32::hislip0::INSTR</InstrumentAddressString>
    <Hostname>10.1.2.32</Hostname>
    <IPAddress>10.1.2.32</IPAddress>
    <SubnetMask>255.255.255.0</SubnetMask>
    <MACAddress>00:3F:F8:6A:1A:3A</MACAddress>
    <Gateway>10.1.2.1</Gateway>
    <DHCPEnabled>true</DHCPEnabled>
    <AutoIPEnabled>true</AutoIPEnabled>
  </Interface>
  <Interface InterfaceType="MyCompanyCustomNetworkInterface"
    InterfaceName="MyCompany1">
    <InstrumentAddressString>10.1.2.32:5025</InstrumentAddressString>
  </Interface>
  <IVISoftwareModuleName>Thingamajig</IVISoftwareModuleName>
  <Extension>
    <SampleExtension>Arbitrary Vendor Extension Data can go here.</SampleExtension>
  </Extension>
  <Domain>1</Domain>
  <LXIVersion>1.5</LXIVersion>
  <LXIExtendedFunctions>
    <Function FunctionName="LXI Wired Trigger Bus" Version="1.0" />
  </LXIExtendedFunctions>
</LXIDevice>
```

```

<Function FunctionName="LXI Event Messaging" Version="1.0" />
<Function FunctionName="LXI Clock Synchronization" Version="1.0" />
<Function FunctionName="LXI Timestamped Data" Version="1.0" />
<Function FunctionName="LXI Event Logs" Version="1.0" />
<Function FunctionName="LXI IPv6" Version="1.0" />
<Function FunctionName="LXI VXI-11" Version="1.0" />
= <Function FunctionName="LXI HiSLIP" Version="1.0">
  <Port>4880</Port>
  </Function>
</LXIExtendedFunctions>
</LXIDevice>

```

LXI Devices with Connected Devices

Rule 10.2.4 addresses LXI Devices that support connected devices, such as bridges. The URLs for all connected devices are found in the ConnectedDevice tags, as in the above example. LXI Devices that support connected devices must provide identification documents for query.

The sample Identification Document above contains two ConnectedDevice URIs. The identification documents for these two devices may be queried by appending “lxi/identification” to the URIs provided. These connected devices are instances of the sample MyIdentification Schema defined above. Note that they reference both the LXI InstrumentIdentification Schema as well as the derived MyIdentificationSchema in the schemalocation attribute.

The first device’s identification document’s URL is

<http://sampledevice.local/devices/device0/lxi/identification>. The document’s contents are:

```

<?xml version="1.0" encoding="UTF-8"?>
<MyDevice xmlns="http://www.mycompany.com/MyIdentification/1.0"
  xmlns:lxi="http://www.lxistandard.org/InstrumentIdentification/1.0"
  xmlns:xsi="http://www.w3.org/2001/XMLSchema-instance"
  xsi:schemaLocation="http://www.lxistandard.org/InstrumentIdentification/1.0
    http://sampledevice.local/static/LXIIdentification.xsd
    http://www.mycompany.com/MyIdentification/1.0
    http://sampledevice.local/static/MyIdentification.xsd" >
  <lxi:Manufacturer>My Company, Inc.</lxi:Manufacturer>
  <lxi:Model>1234</lxi:Model>
  <lxi:SerialNumber>123</lxi:SerialNumber>
  <lxi:FirmwareRevision>1.2.3a</lxi:FirmwareRevision>
  <lxi:IdentificationURL>http://sampledevice.local/devices/device0/lxi/identification</lxi:IdentificationURL>
  <lxi:Interface InterfaceType="MyCompanyProprietary" InterfaceName="instr0">
  <lxi:InstrumentAddressString>TCPIP::10.1.2.32::inst1::INSTR</lxi:InstrumentAddressString>
  </lxi:Interface>
  <lxi:Extension>
  <MySampleDeviceExtension>
    Arbitrary Vendor Extension Data can go here.
  </MySampleDeviceExtension>
  </lxi:Extension>
  <LogicalAddress>0</LogicalAddress>
</MyDevice>

```

The second device's identification document's URL is <http://sampledevice.local/devices/device2/lxi/identification>. The document's contents are:

```
<?xml version="1.0" encoding="UTF-8"?>
<MyDevice xmlns="http://www.mycompany.com/MyIdentification/1.0"
  xmlns:lxi="http://www.lxistandard.org/InstrumentIdentification/1.0"
  xmlns:xsi="http://www.w3.org/2001/XMLSchema-instance"
  xsi:schemaLocation="http://www.lxistandard.org/InstrumentIdentification/1.0
    http://sampledevice.local/static/LXIIdentification.xsd
    http://www.mycompany.com/MyIdentification/1.0
    http://sampledevice.local/static/MyIdentification.xsd" >
  <lxi:Manufacturer>My Company, Inc.</lxi:Manufacturer>
  <lxi:Model>1234</lxi:Model>
  <lxi:SerialNumber>456</lxi:SerialNumber>
  <lxi:FirmwareRevision>1.2.3a</lxi:FirmwareRevision>
  <lxi:IdentificationURL>http://sampledevice.local/devices/device2/lxi/identification</lxi:IdentificationURL>
  <lxi:Interface InterfaceType="MyCompanyProprietary" InterfaceName="instr2">
  <lxi:InstrumentAddressString>TCPIP::10.1.2.32::instr2::INSTR</lxi:InstrumentAddressString>
  <lxi:InstrumentAddressString>TCPIP::10.1.2.32::3002::SOCKET</lxi:InstrumentAddressString>
  </lxi:Interface>
  <lxi:Extension>
  <MySampleDeviceExtension>
  Arbitrary Vendor Extension Data can go here.
  </MySampleDeviceExtension>
  </lxi:Extension>
  <LogicalAddress>2</LogicalAddress>
</MyDevice>
```

7 LXI Discovery Using mDNS

As of Revision 1.3 of the LXI Device Specification, LXI Devices are required to support mDNS, a protocol that allows devices to perform DNS operation on a local link, even without the presence of an administered DNS server. This is useful for setting up simple LANs, allowing devices and controllers to use meaningful Hostnames. In addition, the DNS Service Discovery (DNS-SD) allows servers and clients to advertise, browse, and discover service products – such as HTTP servers, HiSLIP, VXI-11, etc. – on the LAN.

The LXI Discovery Tool provides a means of finding LXI Devices that are advertising themselves, regardless of the subnet configuration.

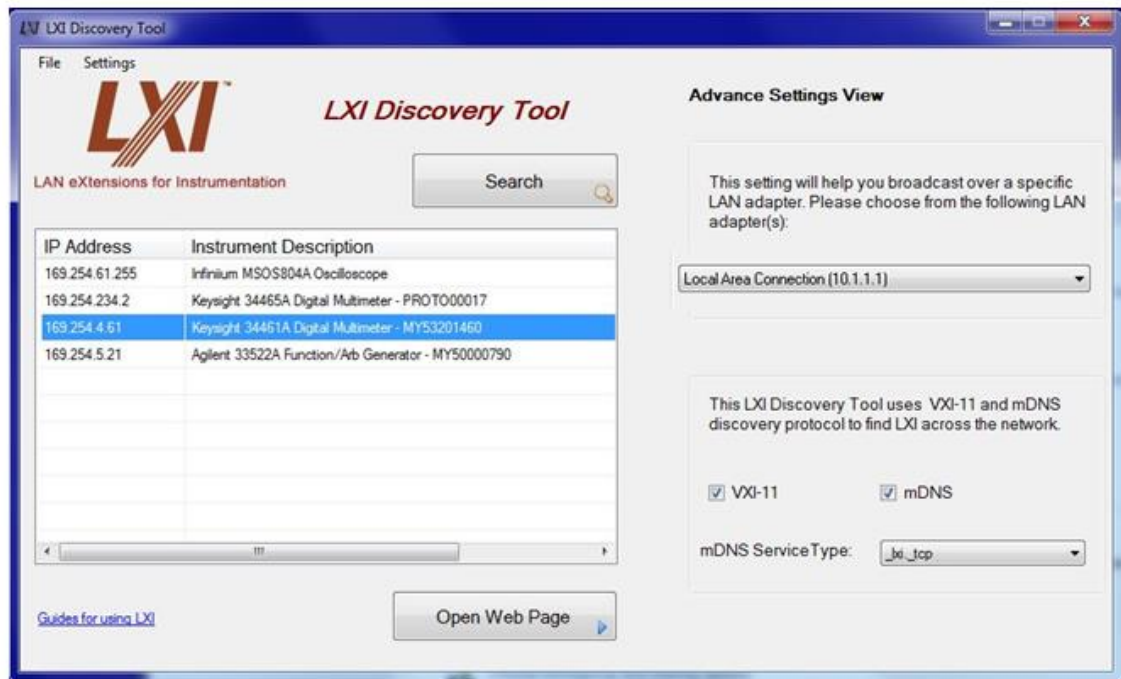

When an LXI Device is connected to a subnet, it immediately starts the advertising process. Other LXI Devices and controllers running the mDNS, DNS-SD, etc. protocol will capture the multicast packets containing the Hostname and Service Name information and will cache that information. They can then perform the name resolution and determine details of the services.

More advanced tools, such as Connection Experts for VISA I/O Libraries, will be running the mDNS service in background of the computer and will discover an LXI Device's service information. The Connection Expert can then present connection choices to the programmer such as HiSLIP, Sockets, VXI-11, etc.

Each LXI Device is required by Rule 10.3 and sub-rules of the LXI Device Specification to resolve its own Hostname and Service Name conflicts when connected to a subnet. The Hostname is typically defaulted to a Model Number concatenated with the device's serial number. The Service Name is often the Description of the device – 6.5 Digit DMM, Spectrum Analyzer, etc.

If an mDNS Hostname conflict occurs, the LXI Device assigns itself a new Hostname and will retry until the conflict is resolved. New Hostnames are generated by appending a number to the end of the hostname. For example, a conflict on "Instr-ABC" would become "Instr-ABC-2" after the first collision, "Instr-ABC-3" on the second, and so on.

If an mDNS Service Name conflict occurs, the LXI Device assigns itself a new Service Name and will retry until the conflict is resolved. New Service Names are generated by appending a number to the end of the service name. For example, a conflict on “Vendor Instrument” would become “Vendor Instrument (2)” after the first collision, “Vendor Instrument (3)” on the second, and so on.

8 Glossary of Terms

Use of Technical Terms



[Link to
Glossary File](#)

The definitions of technical terms and acronyms in this appendix shall be used in interpreting the defined term or acronym in the context of this standard. The embedded file above allows you to obtain the actual glossary document directly.

API

API stands for Application Programming Interface.

Auto-MDIX

Auto-MDIX is a protocol, which allows two Ethernet devices to negotiate their use of the Ethernet TX and RX cable pairs. This allows two Ethernet devices with MDI-X or MDI connectors to connect without using a crossover cable. This feature is also known as Auto-crossover.

ARP

The address resolution protocol (ARP) is a protocol used by the Internet Protocol (IP), specifically IPv4, to map IP network addresses to the hardware addresses used by a data link protocol. It is used when IPv4 is used over Ethernet. The term address resolution refers to the process of finding an address of a computer in a network.

Default gateway

A configuration item for the TCP/IP protocol that is the IP address of a directly reachable IP router. Configuring a default gateway creates a default route in the IP routing table.

DHCP

See definition for: Dynamic Host Configuration Protocol (DHCP)

DNS

See definition for: Domain Name System (DNS)

DNS-SD

DNS Service Discovery. A protocol to advertise instance service names to enable zero address configuration scenarios for networked devices.

DNS server

A server that maintains information about a portion of the Domain Name System (DNS) database and that responds to and resolves DNS queries.

Domain

The term domain is used in three contexts in this specification. See Domain name for the definition in the context of DNS. The term is also used in the LXI Domain to define a scoping mechanism for the processing of LXI Events. For devices implementing IEEE 1588 there is also the concept of an IEEE 1588 domain, which defines a set of IEEE 1588 clocks participating in the IEEE 1588 protocol.

Domain name

In the context of DNS, the name given by an administrator to a collection of networked computers that share a common directory. Part of the Domain Name System (DNS) naming structure, domain names consist of a sequence of name labels separated by periods.

Dynamic Host Configuration Protocol (DHCP)

The Dynamic Host Configuration Protocol provides a framework for passing configuration information to hosts on a TCP/IP network. DHCP is based on the Bootstrap Protocol (BOOTP), adding the capability of automatic allocation of reusable network addresses and additional configuration options. DHCP captures the behavior of BOOTP relay agents, and DHCP participants can interoperate with BOOTP participants. DHCP provides safe, reliable, and simple TCP/IP network configuration, prevents address conflicts, and helps conserve the use of client IP addresses on the network.

DHCP uses a client/server model where the DHCP server maintains centralized management of IP addresses that are used on the network. DHCP-supporting clients can then request and obtain lease of an IP address from a DHCP server as part of their network boot process.

Hostname

A hostname is the unique name by which a network attached device is known on a network. The hostname is used to identify a particular host in various forms of electronic communication such as E-mail or Usenet.

HTML

See definition for: Hypertext Markup Language (HTML)

HTTP

See definition for: Hypertext Transfer Protocol (HTTP)

Hypertext Markup Language (HTML)

A simple markup language used to create hypertext documents that are portable from one platform to another. HTML files are simple ASCII text files with codes embedded (indicated by markup tags) to denote formatting and hypertext links.

Hypertext Transfer Protocol (HTTP)

The protocol used to transfer information on the World Wide Web. An HTTP address (one kind of Uniform Resource Locator [URL]) takes the form: <http://www.w3.org>.

ICMP

Internet Control Message Protocol (ICMP) is a required protocol tightly integrated with IP. ICMP messages, delivered in IP packets, are used for out-of-band messages related to network operation or improper operation.

IEEE

Institute of Electrical and Electronics Engineers. A global technical professional society and standards-setting organization serving the public interest and its members in electrical, electronics, computer, information and other technologies.

IEEE 1588 (PTP)

IEEE 1588 is a standard for a precision clock synchronization protocol for networked measurement and control systems. It is also known as the Precision Time Protocol (PTP).

Front Panel User Interface

A front panel user interface is defined as consisting of control and displays functions, located on the front panel of a device that can be used to set up critical aspects of the LXI interfaces and instrument operation.

Internet Protocol (IP)

A routable protocol in the TCP/IP protocol suite that is responsible for IP addressing, routing, and the fragmentation and reassembly of IP packets.

IP

See definition for: Internet Protocol (IP)

IP address

An address used to identify a node on an IP internetwork. Each node on the IP internetwork must be assigned a unique IP address, which is made up of the network ID, plus a unique host ID. This address is typically represented with the decimal value of each octet separated by a period (for example, 192.168.7.27). You can configure the IP address statically or dynamically by using DHCP.

IVI

IVI stands for Interchangeable Virtual Instrument. The IVI Foundation is an open consortium founded to promote specifications for programming test instruments that simplify interchangeability, provide better performance, and reduce the cost of program development and maintenance.

LAN

See definition for: local area network (LAN)

LCI

LAN Configuration Initialize (LCI) is an LXI Devices recessed reset mechanism (e.g., a button) on the rear or front of the LXI Device that when activated places the LXI Device's network settings to a default state.

Local Area Network (LAN)

A communications network connecting a group of computers, printers, and other devices located within a relatively limited area (for example, a building). A LAN allows any connected device to interact with any other on the network.

LVDS

LVDS stands for Low-Voltage Differential Signaling.

LXI

LXI stands for LAN eXtensions for Instruments. LXI is the next generation instrumentation platform based on industry standard Ethernet technology and provides modularity, flexibility and performance to small- and medium-sized systems.

LXI Device

A device that conforms to this specification, *See also: module*

LXI Event

An event is an abstraction of a change in the realization of a signal or condition. AN LXI Event is an event occurring in an LXI Device or communicated by means of an LXI Event Message.

LXI Event Message

A data packet used for module-to-module communication of LXI Events in an LXI system. The format and semantics of LXI Event Messages are defined in this standard.

LXI Identification XSD Schema

An XML Schema that conforms to XSD standards and is defined by the LXI Consortium to specify XML documents that provide identification information about LXI Devices.

LXI Logo

The LXI Consortium licenses a registered name and logo for use in association with products that are conformant with the standard.

Details of the logo design and the Trademark License Agreement are found in the document(s) “*LXI Consortium Trademark and Patent Policies*”

M-LVDS

Multipoint Low-Voltage Differential Signaling conforming to the TIA/EIA-899 standard, which allows multiple transmitters and receivers to be interconnected on a single, balanced, doubly-terminated media pair. Multipoint operation allows for bidirectional, half-duplex communication between multiple devices connected to the same transmission line.

M-LVDS Type-1

One of two classes of M-LVDS receivers, having a differential input voltage threshold centered about zero volts. Differential input signals below -50 mV are defined by the TIA/EIA-899 standard to be in the low state, and signals above +50 mV are defined to be in the high state. When the input of a Type-1 receiver is connected to an undriven twisted pair, the differential input voltage is defined to be in the threshold transition region. This condition will result in a stable, but undefined, output.

MAC

See definition for: media access control

MAC Address

Media Access Control address. A unique hardware number that identifies each device on a network. A device can be an Instrument, computer, printer, etc.

Media Access Control (MAC)

A sublayer of the IEEE 802 specifications that defines network access methods and framing.

mDNS

One of the discovery protocols specified for use in LXI Devices. mDNS stands for multicast Domain Name Service and is a protocol developed by the IETF Zeroconf Working Group.

MIB

Short for Management Information Base, a database of objects that can be monitored by a network management system. Both SNMP and RMON use standardized MIB formats that allows any SNMP and RMON tools to monitor any device defined by a MIB.

Module

A device that communicates or interacts with an LXI Device. An LXI Device is a special case of a module, *See also: LXI Device*.

Ping

A utility that verifies connections to one or more remote hosts. The ping command uses the ICMP echo request and echo reply packets to determine whether a particular IP system on a network is functional. Ping is useful for diagnosing IP network or router failures.

PoE

IEEE 802.3af Power Over Ethernet is a technology for wired Ethernet LAN that allows the electrical current, necessary for the operation of each device, to be carried by the CAT5 data cables instead of a traditional power cord.

PTP

See definition for IEEE 1588.

Schema

A document that describes a language or parameters of a language. Thus, XML Schemas provide a means of describing the structure, content, and semantics of XML documents.

SCPI

The Standard Commands for Programmable Instrumentation (SCPI) defines a standard set of commands to control programmable test and measurement devices in instrumentation systems. The SCPI Standard is built on the foundation of IEEE-488.2, Standard Codes and Formats.

Simple Network Management Protocol (SNMP)

A network protocol used to manage TCP/IP networks. In Windows, the SNMP service is used to provide status information about a host on a TCP/IP network.

SNMP

See definition for: Simple Network Management Protocol (SNMP)

Subnet

A subdivision of an IP network. Each subnet has its own unique subnetted network ID.

Subnet Mask

A 32-bit value that enables the recipient of IP packets to distinguish the network ID and host ID portions of the IP address. Typically, subnet masks use the format 255.x.x.x.

TCP/IP

See definition for: Transmission Control Protocol/Internet Protocol (TCP/IP)

Transmission Control Protocol/Internet Protocol (TCP/IP)

A set of networking protocols widely used on the Internet that provides communications across interconnected networks of computers with diverse hardware architectures and various operating systems. TCP/IP includes standards for how computers communicate and conventions for connecting networks and routing traffic.

UDP

The User Datagram Protocol (UDP) is one of the core protocols of the Internet protocol suite. Using UDP, programs on networked computers can send short messages known as datagrams to one another.

Uniform Resource Locator (URL)

An address that uniquely identifies a location on the Internet. . Generally, an URL specifies the connection protocol and a file name. The connection protocol can be: telnet, ftp, gopher, etc., and for web pages, http is the usual protocol as in the fictitious URL *http://www.example.microsoft.com*.

URL

See definition for Uniform Resource Locator (URL)

UTC

Coordinated Universal Time (abbreviated UTC) is the basis for the worldwide system of civil time. This time scale is kept by time laboratories around the world, including the U.S. Naval Observatory, and is determined using highly precise atomic clocks.

VISA

Most of the instrument drivers communicate to the instrumentation hardware through an I/O Library. The VISA library is used for the GPIB, VXI, PXI, Serial, Ethernet, and/or USB interfaces, while other buses can utilize either VISA or another library.

W3C

The [World Wide Web Consortium \(W3C\)](http://www.w3.org/) develops interoperable technologies (specifications, guidelines, software, and tools) to lead the Web to its full potential as a forum for information, commerce, communication, and collective understanding.

XSD

An XML Schema Definition, as defined by the W3C (<http://www.w3.org/XML/Schema>). It defines a type of XML document in terms of the constraints upon what elements and attributes may appear, their relationship to each other, what types of data may be in them, and so forth.