



LXI Wired Trigger Bus Extended Function

Revision 1.0

8 November 2016

LXI WIRED TRIGGER BUS EXTENDED FUNCTION	1
REFERENCE DOCUMENTS	3
REVISION HISTORY.....	5
1 OVERVIEW	6
1.1 INTRODUCTION.....	6
1.2 PURPOSE AND SCOPE OF THIS DOCUMENT.....	6
1.2.1 Purpose	6
1.2.2 Scope	6
1.3 DEFINITION OF TERMS.....	7
1.4 ADDITIONAL LXI CONFORMANCE REQUIREMENTS.....	8
1.4.4 Extended Functions	8
2 PHYSICAL SPECIFICATIONS.....	9
2.4 ELECTRICAL STANDARDS.....	9
2.4.10 LXI Wired Trigger Bus Connectors	9
5 LXI DEVICE WIRED TRIGGER BUS	10
5.1 INTRODUCTION.....	10
5.2 RULE - LXI WIRED TRIGGER BUS CABLE AND TERMINATION SPECIFICATION.	12
5.3 ELECTRICAL REQUIREMENTS	12
5.3.1 RULE – Number of Channels.....	12
5.3.2 RULE – Signaling Standard	12
5.3.3 RULE – LXI Wired Trigger Bus Buffering.....	12
5.3.4 RULE – M-LVDS Transceiver Type.....	12
5.3.5 RULE – Input / Output Configurability.....	12
5.3.6 RULE – Drive Mode Configurability	12
5.3.7 RULE – Driver Topology	12
5.3.8 RULE – Wired-OR Bias.....	14
5.3.9 RULE – Wired-OR Bias Device.....	14
5.3.10 RULE – Wired-OR Bias Device Functionality	14
5.3.11 RULE – Power-up Default Configuration	14
5.3.14 RULE - Signal Routing to All Eight Channels	14
5.3.15 RULE – Simultaneous Transmit and Receive	15
5.3.16 Recommendation – Gating of Unwanted Receiver Outputs	15
5.3.19 RULE – Documentation of Minimum Trigger Pulse Width.....	15
5.4 PHYSICAL REQUIREMENTS	16
5.4.1 RULE – LXI Wired Trigger Bus Connector Type	16
5.4.2 Recommendation – LXI Wired Trigger Bus Connector Type.....	16
5.4.3 RULE – Number of LXI Wired Trigger Bus Ports.....	16
5.4.4 Permission – Additional LXI Wired Trigger Bus Ports.....	17
5.4.5 RULE – Trace Characteristic Impedance	17
5.4.6 RULE – Printed Circuit Trace Lengths	17
5.4.7 RULE – Channel-to-Channel Skew.....	17
5.4.8 RULE – Maximum Stub Length.....	17
5.4.9 RULE – LXI Wired Trigger Bus Connector Pin Assignments.....	18
5.4.10 Recommendation – +3.3V Protection Using Self-Healing Fuse	18
5.4.11 RULE – Reserved Pins Shall Not Be Used For Other Purposes.....	19

Reference Documents

Notice of Rights All rights reserved. This document is the property of the LXI Consortium. It may be reproduced, unaltered, in whole or in part, provided the LXI copyright notice is retained on every document page.

Notice of Liability The information contained in this document is subject to change without notice. “Preliminary” releases are for specification development and proof-of-concept testing and may not reflect the final “Released” specification.

The LXI Consortium, Inc. makes no warranty of any kind with regard to this material, including but not limited to, the implied warranties of merchantability and fitness for a particular purpose. The LXI Consortium, Inc. shall not be liable for errors or omissions contained herein or for incidental or consequential damages in connection with the furnishing, performance, or use of this material.

LXI Standards Documents are developed within the LXI Consortium and LXI Technical Working Groups sponsored by the LXI Consortium Board of Directors. The LXI Consortium develops its standards through a consensus development process modeled after the American National Standards Institute, which brings together volunteers representing varied viewpoints and interests to achieve the final product. Volunteers are not necessarily members of the Consortium and serve without compensation. While the LXI Consortium administers the process and establishes rules to promote fairness in the consensus development process, the LXI Consortium does not exhaustively evaluate, test, or verify the accuracy of any of the information contained in its standards.

Use of an LXI Consortium Standard is wholly voluntary. The LXI Consortium and its members disclaim liability for any personal injury, property or other damage, of any nature whatsoever, whether special, indirect, consequential, or compensatory, directly or indirectly resulting from the publication, use of, or reliance upon this, or any other LXI Consortium Standard document.

The LXI Consortium does not warrant or represent the accuracy or content of the material contained herein, and expressly disclaims any express or implied warranty, including any implied warranty of merchantability or fitness for a specific purpose, or that the use of the material contained herein is free from patent infringement. LXI Consortium Standards documents are supplied “as is”. The existence of an LXI Consortium Standard does not imply that there are no other ways to produce, test, measure, purchase, market, or provide other goods and services related to the scope of the LXI Consortium Standard. Furthermore, the viewpoint expressed at the time a standard is approved and issued is subject to change brought about through developments in the state of the art and comments received from users of the standard. Every LXI Consortium Standard is subjected to review at least every five years for revision or reaffirmation. When a document is more than five years old and has not been reaffirmed, it is reasonable to conclude that its contents, although still of some value, do not wholly reflect the present state of the art. Users are cautioned to check to determine that they have the latest edition of any LXI Consortium Standard.

In publishing and making this document available, the LXI Consortium is not suggesting or rendering professional or other services for, or on behalf of, any person or entity. Nor is the LXI Consortium undertaking to perform any duty owed by any other person or entity to another. Any person utilizing this, and any other LXI Consortium Standards document, should rely upon the advice of a competent professional in determining the exercise of reasonable care in any given circumstances.

This specification is the property of the LXI Consortium, a Delaware 501c3 corporation, for the use of its members.

Interpretations Occasionally questions may arise regarding the meaning of portions of standards as they relate to specific applications. When the need for interpretations is brought to the attention of LXI Consortium, the Consortium will initiate action to prepare appropriate responses. Since LXI Consortium Standards represent a consensus of concerned interests, it is important to ensure that any interpretation has

also received the concurrence of a balance of interests. For this reason, LXI Consortium and the members of its working groups are not able to provide an instant response to interpretation requests except in those cases where the matter has previously received formal consideration. Requests for interpretations of this standard must be sent to interpretations@lxistandard.org using the form “*Request for Interpretation of an LXI Standard Document*”. This document plus a list of interpretations to this standard are found on the LXI Consortium’s Web site: <http://www.lxistandard.org>

Trademarks Product and company names listed are trademarks or trade names of their respective companies. No investigation has been made of common-law trademark rights in any work.

LXI is a registered trademark of the LXI Consortium

Patents: Attention is drawn to the possibility that some of the elements of this document may be the subject of patent rights. A holder of such patent rights has filed a copy of the document “*Patent Statement and Licensing Declaration*” with the Consortium. By publication of this standard, no position is taken with respect to the existence or validity of any patent rights in connection therewith. Other patent rights may exist for which the LXI Consortium has not received a declaration in the form of the document “*Patent Statement and Licensing Declaration*”. The LXI Consortium shall not be held responsible for identifying any or all such patent rights, for conducting inquiries into the legal validity or scope of patent rights, or determining whether any licensing terms or conditions are reasonable or non-discriminatory. Users of this standard are expressly advised that determination of the validity of any patent rights, and the risk of infringement of such rights, is entirely their own responsibility.

Conformance The LXI Consortium draws attention to the document “*LXI Consortium Policy for Certifying Conformance to LXI Consortium Standards*”. This document specifies the procedures that must be followed to claim conformance with this standard.

Legal Issues Attention is drawn to the document “*LXI Consortium Trademark and Patent Policies*”. This document specifies the requirements that must be met in order to use registered trademarks of the LXI Consortium.

Revision history

<i>Revision</i>	<i>Description</i>
1.0 Version	Initial Release November 8, 2016

1 Overview

1.1 Introduction

The LXI Wired Trigger Bus (WTB) is a hardwired interface to specify input or output configurability, wired-OR, and shielding and cabling for the most demanding triggering applications. This method of triggering increases your accuracy to the nanosecond range compared to software triggering via the LAN, which is typically in the millisecond range.

The LXI Device Wired Trigger Bus implements a cabling system to interconnect multiple LXI Devices. The physical interface builds upon the TIA/EIA-889 Multipoint Low Voltage Differential Signaling (M-LVDS) standard. This standard uses differential current driven signals to exchange data between semiconductor devices. Each LXI Device supporting the LXI Wired Trigger Bus has a minimum of two Trigger Bus connectors. This provides a pass-through connection of the bus by routing signals through each participating instrument. A termination device is required at the end of each LXI Wired Trigger Bus connection segment, provided by the LXI Wired Trigger Bus Terminator.

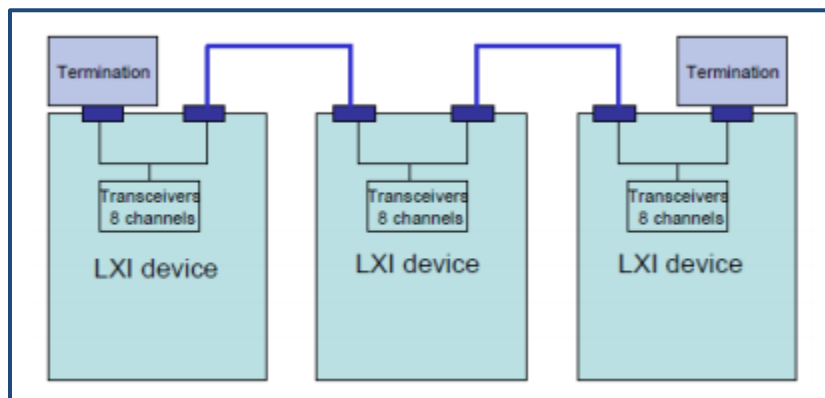

1.2 Purpose and Scope of this Document

1.2.1 Purpose

Each LXI Extended Function has its own document with unique section numbering that, if merged with the LXI Specification Core document, would produce a contiguous representation of the entire LXI Specification. .

This document specifies the requirements for conformance to the LXI Wire Trigger Bus Extended Function.

1.2.2 Scope

This document defines a common set of **RULES** and **RECOMMENDATIONS** for constructing a conformant LXI Device with one or more Extended Functions. Whenever possible these specifications use existing industry standards.

The original LXI Device Specification included both requirements for all LXI Devices and a number of Extended Functions in a single document. Common information moves to LXI Extended

Function Common Document and specific information related to the Extended Function move to separate documents. Therefore, to keep references to Section numbers, Rule numbers, Permissions, Recommendations, etc. the same as the original LXI Specification document, some sections are place holders within this document and only provide a means to keep Rule and Sections numbers the same as the original LXI Device Specification.

1.3 Definition of Terms

This document contains both normative and informative material. Unless otherwise stated the material in this document shall be considered normative.

NORMATIVE: Normative material shall be considered in determining whether an LXI Device is conformant to this standard. Any section or subsection designated as a **RULE** or **PERMISSION** is normative.

INFORMATIVE: Informative material is explanatory and is not considered in determining the conformance of an LXI Device. Any section or subsection designated as **RECOMMENDATION**, **SUGGESTION**, or **OBSERVATION** is informative. Unless otherwise noted examples are informative.

RULE: Rules **SHALL** be followed to ensure compatibility for LAN-based devices. A rule is characterized by the use of the words **SHALL** and **SHALL NOT**. These words are not used for any other purpose other than stating rules.

RECOMMENDATION: Recommendations consist of advice to implementers that will affect the usability of the final device. Discussions of particular hardware to enhance throughput would fall under a recommendation. These should be followed to avoid problems and to obtain optimum performance.

PERMISSION: Permissions are included to clarify the areas of the specification that are not specifically prohibited. Permissions reassure the reader that a certain approach is acceptable and will cause no problems. The word **MAY** is reserved for indicating permissions.

OBSERVATION: Observations spell out implications of rules and bring attention to things that might otherwise be overlooked. They also give the rationale behind certain rules, so that the reader understands why the rule must be followed. Any text that appears without heading should be considered as description of the specification.

1.4 Additional LXI Conformance Requirements

1.4.4 Extended Functions

1.4.4.1 General Description

The LXI Standard consists of the LXI Device Specification, required for all LXI Devices. In addition, it includes all optional Extended Functions.

LXI Extended Functions

Extended Functions come in the form of external documents. Each Extended Function document will have sections numbered as though they were part of the LXI Device Specification, but the documents are separate to simplify maintenance of the standard and add new Extended Functions without altering the LXI Device Specification. The [Guide to LXI Documentation](#) identifies the Extended Function documents.

1.4.4.2 Conformance Requirements

The rules in this document define the conformance requirements for this Extended Function. In addition to the requirements for all LXI Devices found in the *LXI Device Specification*, an Extended Function may require conformance to another Extended Function. All these requirements are detailed in the following Rule.

1.4.4.2.3 RULE – LXI Wired Trigger Bus Conformance Requirements

LXI Device Specification Document:

- All LXI Devices shall conform to the rules found in Section 1.4 and all subsections
- Sections 3.5 and 3.7, including all subsections
- Section 6.1.1, sections 6.3 through 6.4.2 including all subsections, and 6.4.4 through 6.4.6, including all subsections
- Section 9.6 including all subsections
- A Function element with the FunctionName attributes of “LXI Wired Trigger Bus” and version “1.0” in the LXIExtendedFunction element of the LXI identification document as described by section 10.2.5

LXI Wired Trigger Bus Extended Function (this Document):

- Include all rules

2 Physical Specifications

The LXI Device Specification details the physical requirements for LXI Device conformance. When adding the LXI Wired Trigger Bus, there are requirements added to the physical specification, as indicated below in Section 2.4.10.

2.4 Electrical Standards

2.4.10 LXI Wired Trigger Bus Connectors

2.4.10.1 RULE – LXI Wired Trigger Bus Connectors

For devices incorporating the LXI Wired Trigger Bus, the number and type of LXI Wired Trigger Bus connectors shall be as specified in Section 5.

2.4.10.2 Recommendation – Connector Location

Location of the LXI Wired Trigger Bus connectors should be on the rear panel of the device at the right hand edge as constrained by the location of the power connector.

2.4.10.3 Recommendation – Connector Orientation

The LXI Wired Trigger Bus connectors should be vertically stacked with a minimum vertical, center-to-center, separation of 11.05mm (0.435 inches).

2.4.10.4 Permission – Connector Orientation

The LXI Wired Trigger Bus connectors may be horizontally mounted immediately next to each other.

2.4.10.5 Permission – Vendor-Specific Triggers

Vendor-specific hardware trigger interfaces are permitted

5 LXI Device Wired Trigger Bus

5.1 Introduction

The LXI Device Wired Trigger Bus implements a cabling system to interconnect multiple LXI Devices. The physical interface builds upon the TIA/EIA-889 Multipoint Low Voltage Differential Signaling (M-LVDS) standard. This standard uses differential current driven signals to exchange data between semiconductor devices. Each LXI Device supporting the LXI Wired Trigger Bus has a minimum of two Trigger Bus connectors. This provides a pass-through connection of the bus by routing signals through each participating instrument. A termination device is required at the end of each LXI Wired Trigger Bus connection segment, provided by the LXI Wired Trigger Bus Terminator. The terminator attaches to the second connector at each segment end, as seen in Figure 5.1.

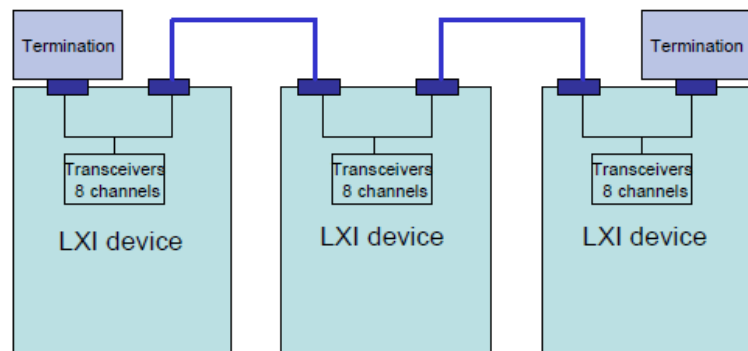

Figure 5.1 Configuration of LXI Devices using the LXI Wired Trigger Bus

The LXI Wired Trigger Bus provides eight physically independent trigger channels, matching the number of logical channels provided by the LXI Event Message mechanism in the LXI standard. The LXI Wired Trigger Bus designates LXI0 to LXI7, while the LXI Event Message designates identifiers LAN0 to LAN7.

Trigger events made through the LXI Wired Trigger Bus or the LXI Event Message trigger system are interchangeable, since the trigger model is consistent in each mode of operation.

Triggering within and between LXI devices varies widely between applications, and several examples of possible trigger scenarios are as follows:

- Internal or external events generate a trigger signal to initiate an action in a device.
- A computer sends a trigger signal event that initiates an action in a device.
- One device sends an LXI Event-based trigger signal to one or more other devices.
- LXI Event-based triggers received by one or more devices cause hardware triggers to be sent to one or more other devices
- A hardware trigger signal is time-stamped by a device and synchronizes other actions
- A common reference clock, distributed using hardware trigger lines, synchronizes actions in multiple devices.

There are important differences in performance between the LXI Wired Trigger Bus and LXI Event Messages. LXI Event Messages are LAN-based and depend upon the LAN driver, LAN speed, software interrupts, and processor speed. The LXI Wired Trigger Bus is a dedicated bus interface with the following characteristics:

- Hardware delays on the bus cables and associated routing logic dominate the trigger delay between an event and the initiation of an action at another node
- LXI Devices connect the trigger bus signals as directly as possible from the interface to the hardware performing the task.
- Once set up there is virtually no software or firmware related delays in reaction times.

The LXI Wired Trigger Bus exhibits both low trigger delay and low trigger jitter and performance levels not achievable through the LAN based trigger mechanisms. In addition to supporting high performance trigger operations, the trigger bus can also exchange clock signals or other data signals between LXI Devices.

Each channel of the LXI Wired Trigger Bus is capable of operating in one of two modes and set by programming the LXI Devices that are taking part in the trigger operation for that channel. LXI Devices that are not taking part in a trigger operation would have their LXI Wired Trigger Bus drivers disabled. The two modes of operation are:

- **Driven Mode.** This provides point-to-multipoint operation. One device initiates a trigger event to one or more receiving devices. This mode uses one driver per LXI Device for each LXI Wired Trigger Bus channel.
- **Wired-OR Mode.** This is a multipoint-to-multipoint operation. One or more devices initiate a trigger event to one or more receiving devices. The Wired-OR Mode requires one device to be the Wired-OR Bias Device, and its driver provides a bias for the LXI Wired Trigger Bus channel. Other devices participating in the wired trigger require the use of two drivers for each LXI Wired Trigger Bus channel, so they can both transmit and receive their own signals.

The remainder of this section will focus on the required operation of LXI Devices that implement the LXI Wired Trigger Bus. Requirements related to the construction of cables, proper termination, electrical adapter components, trigger distribution hubs, and physical device-to-device electrical performance is located in the document “*LXI Wired Trigger Bus Cable and Terminator Specifications*”

5.2 **RULE - LXI Wired Trigger Bus Cable and Termination Specification.**

Each LXI Device implementing the LXI Wired Trigger Bus shall meet the interconnect requirements in the document “*LXI Wired Trigger Bus Cable and Terminator Specifications*” in order to assure proper device operation within a system consisting of other LXI Devices implementing the LXI Wired Trigger Bus.

5.3 **Electrical Requirements**

5.3.1 **RULE – Number of Channels**

LXI Devices implementing the LXI Wired Trigger Bus shall support all eight hardware channels.

5.3.2 **RULE – Signaling Standard**

Each LXI Wired Trigger Bus channel shall use half-duplex, Multipoint-Low-Voltage-Differential Signaling (M-LVDS) with Type-1 receivers, compliant with TIA/EIA-899.

5.3.3 **RULE – LXI Wired Trigger Bus Buffering**

Each LXI Device connected to the LXI Wired Trigger Bus shall provide half-duplex buffering on each channel, between the external M-LVDS pair and the internal signal routing of the LXI Device.

5.3.4 **RULE – M-LVDS Transceiver Type**

One of the following M-LVDS transceivers shall be used for the LXI Wired Trigger Bus: Texas Instruments SN65MLVD080 (8 channel) or Texas Instruments SN65MLVD201 (single channel).

5.3.5 **RULE – Input / Output Configurability**

Each LXI Wired Trigger Bus channel shall be individually configurable as an input or output (or both), and shall be capable of being individually enabled or disabled.

5.3.6 **RULE – Drive Mode Configurability**

Each LXI Wired Trigger Bus driver shall be individually configurable to operate in either Driven or Wired-OR Mode.

5.3.7 **RULE – Driver Topology**

Each LXI Wired Trigger Bus driver shall consist of two M-LVDS drivers with the outputs connected in parallel, as shown in Figure 5.2b. In Driven Mode, only one driver shall be enabled, and the trigger signal shall be applied to the driver’s input. In Wired-OR Mode, each driver shall be configured to drive current from the positive (A) output to the negative (B) output when enabled, and the trigger signal shall be applied to the enable inputs of both drivers.

Observation – Wired-OR Signaling

In Driven Mode, only one of the two parallel drivers is enabled, and the trigger signal is applied to the input pin of the enabled driver (the input to the disabled driver can be either high or low). The differential trigger lines are driven to the high or low state by sourcing (positive) or sinking (negative) current through the termination resistors.

In Wired-OR Mode, both parallel drivers are used with their input pins held high, and the trigger signal is applied to the enable pins of both drivers. The differential trigger lines are driven to the high or low state by sourcing (positive) or turning off current to the termination resistors (see Figure 5.2a). To improve the noise margin, a single driver in one of the connected LXI Devices (referred to as the Wired-OR Bias Device) can be programmatically configured to drive a constant negative current through the termination resistors, thus forcing the trigger lines low when all of the other drivers on the bus are disabled. The parallel driver topology used in this mode is required to overcome the negative bias current, resulting in a net positive current through the termination. Note that the Wired-OR Bias Device may still participate in Wired-OR signaling, but unlike all of the other devices on the bus, it operates its driver in Driven Mode, rather than Wired-OR Mode.

Caution should be exercised when using a channel operating in Wired-OR Mode which has a Bias Device that participates in the Wired-OR signaling, particularly in applications requiring edge detection. Under some conditions, it is possible, due to non-linear properties in the drivers and the distributed nature of the bus, for false pulses on the order of 10-20 ns to be generated when the Bias Device changes state. In such situations, depending on the application, additional steps may be required to prevent undesired behavior, such as deglitching the received signal using additional logic, re-sampling the bus 50-100 ns after an edge transition, or by using reflected-wave switching. Note that this effect does not occur in the more typical situation where the Bias Device is not participating in the Wired-OR signaling, and thus should only be of concern in situations where all of the devices on the bus are required to participate.

The alternate Wired-OR topology shown in Figure 5.2b may be advantageous when designing a printed circuit board layout. In that topology, the inputs to the drivers have opposite levels, and the positive output (A) of one driver is connected to the negative output (B) of the other driver, and vice versa. This alternative topology is particularly advantageous if the driver IC's are placed on opposite sides of the printed circuit board, and each LXI Wired Trigger Bus channel uses one driver from each IC.

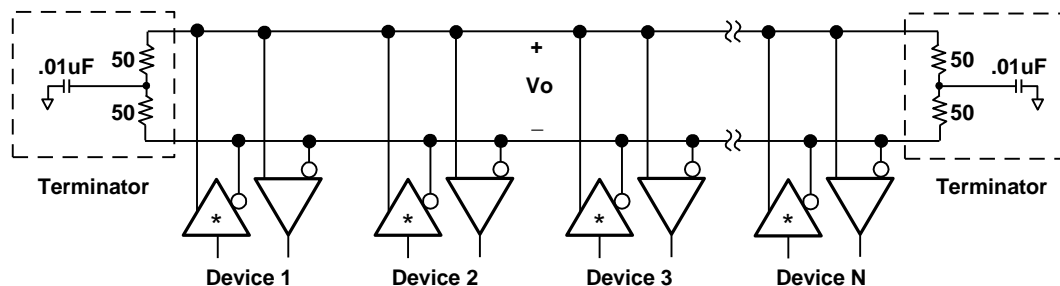

(*See Fig 5.2b for driver configuration)

Figure 5.2 a) Single LXI Wired Trigger Bus Channel with Bus Terminators

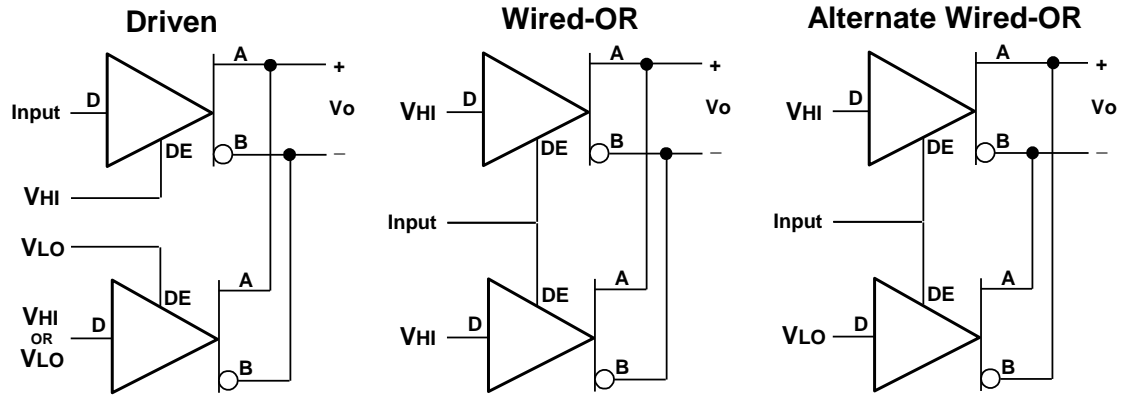

Figure 5.2 b) LXI Wired Trigger Bus Drivers, Driven and Wired-OR Modes

5.3.8 RULE – Wired-OR Bias

Each LXI Wired Trigger Bus channel configured for Wired-OR Mode operation shall be configurable to receive a Wired-OR Bias by any one of the LXI Devices connected to the bus.

5.3.9 RULE – Wired-OR Bias Device

Each LXI Device connected to the LXI Wired Trigger Bus shall be configurable to act as the Wired-OR Bias Device for any number of LXI Wired Trigger Bus channels configured for Wired-OR operation. The Wired-OR Bias Device shall be capable of enabling and disabling the Wired-OR Bias under programmatic control and on a channel-by-channel basis.

Observation – Wired-OR Bias Device

In the case where there are multiple channels configured for Wired-OR operation, a single LXI Device can provide the Wired-OR Bias for all necessary channels, or the bias for different channels can be provided by different LXI Devices. In either case, the LXI Device providing the bias for a given channel is the Wired-OR Bias Device for that channel.

5.3.10 RULE – Wired-OR Bias Device Functionality

The LXI Wired Trigger Bus driver of an LXI Device configured to act as the Wired-OR Bias Device for a particular channel shall always operate in Driven Mode. It shall drive the LXI Wired Trigger Bus channel low (negative), unless it is participating in the Wired-OR communication, in which case it shall actively drive the bus according to its input. (Refer to the Driven-Mode Driver schematic in Figure 5.2b).

5.3.11 RULE – Power-up Default Configuration

All LXI Wired Trigger Bus channels shall default to the disabled configuration when power is applied to the LXI device.

5.3.14 RULE - Signal Routing to All Eight Channels

Any LXI Device capable of transmitting or receiving signals on the LXI Wired Trigger Bus shall be capable of doing so on any of the eight LXI Wired Trigger Bus channels.

Observation – Signal Routing to All Eight Channels

This rule requires that any LXI Device using the LXI Wired Trigger Bus must be capable of routing trigger signals to or from any of the eight channels. This eliminates the possibility of conflicting channel use restrictions by different vendors.

5.3.15 RULE – Simultaneous Transmit and Receive

LXI Devices using the LXI Wired Trigger Bus shall be capable of simultaneously transmitting and receiving signals on any of the eight LXI Wired Trigger Bus channels.

Observation – Transmitting and Receiving the Same Signal

The ability of a device to receive its own transmitted LXI Wired Trigger Bus signal is useful for such purposes as diagnostics or trigger delay management.

5.3.16 Recommendation – Gating of Unwanted Receiver Outputs

In cases when it is not possible to disable individual receivers, unwanted receiver output signals should be gated inside the LXI Device, using additional logic, to stop the input signal from affecting internal trigger circuitry.

Observation – Receiver Output Gating Function

When there is intentional activity on an LXI Wired Trigger Bus channel that an LXI Device is not currently using, the gating function in the device is used to prevent that activity from causing undesired device behavior. Furthermore, if no LXI Devices on the bus are actively driving a particular channel, the input signal levels of any receivers connected to it will lie very close to their threshold levels. This condition can result in unintended receiver output activity that should be gated inside the device.

5.3.19 RULE – Documentation of Minimum Trigger Pulse Width

Manufacturers shall provide documentation specifying the minimum pulse width required by an LXI Device to achieve reliable triggering when using edge detection.

Observation – Waiting for Trigger and Measurement Complete

The Arm-Trigger State Machine discussed in Section 6, The LXI Programmatic Interface, of the LXI Extended Function Common document outlines the need to support Waiting for Trigger and Measurement Complete, which are necessary to provide synchronization of this LXI Device with other LXI Devices in the system.

5.4 Physical Requirements

5.4.1 RULE – LXI Wired Trigger Bus Connector Type

25-pin Micro-D connectors shall be used to interconnect LXI Devices incorporating the LXI Wired Trigger Bus.

5.4.2 Recommendation – LXI Wired Trigger Bus Connector Type

The following connectors, or equivalents, are representative of the type recommended for LXI Wired Trigger Bus connectivity: ITT Cannon MDSM-25PE-Z10-VR17 (single connector) or Molex 83619-9011 (dual connector). These connectors can be double-stacked in a 1U configuration for efficient space utilization.

Observation – Connector Performance

While both single and double-stacked connectors are acceptable, better performance is achievable using double-stacked connectors, due to their compact size.

5.4.3 RULE – Number of LXI Wired Trigger Bus Ports

All LXI Devices implementing the LXI Wired Trigger Bus shall have at least one LXI Wired Trigger Bus port, consisting of a pair of LXI Wired Trigger Bus connectors wired in parallel (like-numbered pins connected together). (See Section 2 for recommended connector locations).

5.4.4 Permission – Additional LXI Wired Trigger Bus Ports

LXI Devices may have more than one LXI Wired Trigger Bus port, provided that each port consists of a single pair of LXI Wired Trigger Bus connectors wired in parallel (like-numbered pins connected together), and that each port provides the required buffering, as defined in Section 5.3.8.

Observation – Additional LXI Wired Trigger Bus Ports

While it is permissible to have more than one LXI Wired Trigger Bus port on an LXI Device, it is not recommended. Implement with caution. Consider the following points for additional ports.

- a) Count each port (connector pair) on an LXI Device as a separate node. This helps in determining the number of LXI Wired Trigger Bus nodes on a connection point.
- b) Do not assume the LXI Programmatic Interface supports more than one LXI Wired Trigger Bus port on an LXI Device. Consult the most current versions of the following LXI Consortium documents before implementing additional ports: see Sections 6 and 9 of this document and the “IVI-3.15: IviLxiSync Specification.”
- c) Perform tests on each port individually to verify compliance with all of the requirements in Section 5 of the LXI Specification.
- d) Clearly identify the pairing of LXI Wired Trigger Bus connectors to avoid user confusion.

5.4.5 RULE – Trace Characteristic Impedance

Traces interconnecting the LXI Wired Trigger Bus connector pins shall be designed for 100-ohms ($\pm 10\%$) differential characteristic impedance.

5.4.6 RULE – Printed Circuit Trace Lengths

Traces interconnecting the LXI Wired Trigger Bus connector pins shall be kept as short as possible, with a maximum trace length of 63.5 mm (2.5 inches) between connectors.

5.4.7 RULE – Channel-to-Channel Skew

Inside the LXI Device, Traces interconnecting the LXI Wired Trigger Bus connectors shall be kept as equal in length as possible, with a trace length difference between channels (maximum-to-minimum) of less than 25 mm.

Observation – Channel-to-Channel Skew

This rule is included to ensure that the channel-to-channel timing skew introduced by the LXI Device is less than 200 ps.

5.4.8 RULE – Maximum Stub Length

If a stub is created as a result of connecting the LXI Wired Trigger Bus to a transceiver, the maximum stub length shall not exceed 12.7 mm (0.5 inches).

5.4.9 **RULE – LXI Wired Trigger Bus Connector Pin Assignments**

LXI Wired Trigger Bus connectors and cables shall use the pin assignments shown in Table 5.1.

5.4.9.1 **RULE – +3.3V Supply on LXI Wired Trigger Bus Connectors**

Each LXI Wired Trigger Bus connector shall provide +3.3 V (± 0.2 V), capable of sourcing a total minimum current of 100 mA for both connectors (not 100 mA on each connector). The power supply shall be short circuit protected.

Observation – +3.3V Supply Usage

The +3.3V supply on LXI Wired Trigger Bus connectors is useful for such purposes as powering vendor-specific adaptors or other similar devices. Note that the +3.3V and +3.3V_RETURN pins are not connected in LXI Wired Trigger Bus cables and are thus only available directly from the connectors.

5.4.10 **Recommendation – +3.3V Protection Using Self-Healing Fuse**

It is recommended the +3.3V power pin on each LXI Wired Trigger Bus connector be protected by a separate self-healing fuse.

5.4.11 RULE – Reserved Pins Shall Not Be Used For Other Purposes

Pins designated as “Reserved” shall not be used for any purpose that is not specifically authorized by the LXI Consortium.

Table 5.1 LXI Wired Trigger Bus Pin Assignments

Pin	Signal
1	+3.3V
2	+3.3V_RETURN
3	LXI1p
4	LXI1n
5	GND
6	LXI3p
7	LXI3n
8	GND
9	LXI5p
10	LXI5n
11	Reserved
12	LXI7p
13	LXI7n
14	LXI0p
15	LXI0n
16	Reserved
17	LXI2p
18	LXI2n
19	GND
20	LXI4p
21	LXI4n
22	GND
23	LXI6p
24	LXI6n
25	Reserved
Connector Shell	CHASSIS

Note: LXI Wired Trigger Bus signals with a “p” suffix are the positive (A) half of the pair and those with an “n” suffix are the negative (B) half.