



# **LXI Device Specification 2023**

Revision 1.6.1

January 18, 2024

<b>LXI DEVICE SPECIFICATION 2023</b> .....	<b>1</b>
<b>REVISION HISTORY</b> .....	<b>7</b>
<b>1 OVERVIEW</b> .....	<b>8</b>
1.1 INTRODUCTION.....	8
1.2 PURPOSE AND SCOPE OF THIS DOCUMENT.....	8
1.2.1 Purpose .....	8
1.2.2 Scope .....	8
1.2.3 Changes from previous LXI Device Specifications.....	9
1.3 DEFINITION OF TERMS.....	9
1.3.1 Use of the Term <i>default</i> .....	10
1.4 APPLICABLE STANDARDS AND DOCUMENTS .....	10
1.4.1 RULE – Applicable Version of Documents .....	10
1.4.2 Standards and Specifications .....	10
1.4.3 LXI Consortium Supplementary Documents.....	12
1.4.4 LXI Device Specification and Extended Functions .....	12
1.4.5 RULE – Functional Declaration .....	14
1.4.6 RULE – Web Indication of Functional Declaration .....	14
1.4.7 RULE – Terms Using the LXI Trademark .....	15
<b>2 LXI PHYSICAL SPECIFICATIONS</b> .....	<b>16</b>
2.1 INTRODUCTION.....	16
2.4 ELECTRICAL STANDARDS.....	16
2.4.5 LAN Configuration Initialize (LCI) .....	16
2.4.9 LAN Connectors.....	17
2.5 ELECTRICAL STANDARDS – STATUS INDICATORS .....	18
2.5.1 Power Indicator.....	19
2.5.2 LAN Status Indicator .....	20
2.6 LXI DEVICE AND DOCUMENTATION LABELING REQUIREMENTS .....	21
<b>3 LXI DEVICE SYNCHRONIZATION AND EVENTS</b> .....	<b>23</b>
3.1 INTRODUCTION.....	23
3.5 LXI EVENT HANDLING.....	24
3.5.1 RULE – Measurement-related Functions Initiated by LXI Events.....	24
3.5.2 Recommendation – Trigger Outputs Can Be Transmitted by Any Method .....	26
3.7 RULE– INTERNAL LOG FILE FOR EVENTS.....	27
3.7.1 Recommendation – Events to Be Logged.....	28
<b>4 DEVICE-TO-DEVICE DATA COMMUNICATION OF LXI EVENT MESSAGES</b> .....	<b>29</b>
<b>5 LXI DEVICE WIRED TRIGGER BUS</b> .....	<b>30</b>
<b>6 LXI PROGRAMMATIC INTERFACE (DRIVERS)</b> .....	<b>31</b>
6.1 RULE – IVI DRIVER REQUIREMENT .....	31
6.1.1 RULE – Trigger and Event Required API.....	31
6.2 RULE – SYNTAX OF THE DEVICE ADDRESS .....	32
6.3 RULE – IVI PROPERTY FOR REFERENCING A SIGNAL SOURCE .....	34
6.4 RULE – EIGHT LXI EVENTS FOR ARM/TRIGGER AND EIGHT FOR LXI EVENT MESSAGES.....	34
6.4.1 Recommendation – Adding Additional Arm/Trigger Sources and Events.....	34
6.4.2 RULE –IVI-3.15 IviLxiSync API Routes Events to LAN.....	34
6.4.3 RULE – LXI Events Encode the Sense of the Event in Packet .....	34
6.4.4 RULE – Standard Strings Used to Designate Events .....	35
6.4.5 RULE – LXI Event Names Beginning with LXI Reserved.....	38
6.4.6 RULE – Destination Path Syntax .....	38
6.4.7 Recommendation – Create TCP Event Connections in Advance .....	38
6.5 RULE – API TIME REPRESENTATION.....	39
6.5.1 Deprecated RULE – Property Names for Real-Time Representation.....	39

6.5.2	Deprecated RULE – Property Names for Real-Time Timestamp.....	39
6.5.3	Recommendation – Use a Single Timestamp for Data Sets .....	39
6.6	RULE – DOMAIN PROPERTY TO FACILITATE MULTIPLE SYSTEMS ON A SINGLE LAN.....	39
6.6.1	Recommendation – Domain Property Is Persistent .....	39
6.6.2	Recommendation – Location of Domain Property in API.....	39
6.8	RECOMMENDATION – CONTROL IDENTIFICATION LIGHT.....	40
<b>7</b>	<b>LAN SPECIFICATIONS.....</b>	<b>41</b>
7.1	RULE – ETHERNET REQUIRED.....	41
7.1.1	Recommendation - Gigabit Ethernet .....	41
7.1.2	RULE – Proper Operation in Slower Networks .....	41
7.2	RULE – MAC ADDRESS DISPLAY .....	41
7.2.1	Recommendation – MAC Address Visible While in Rack.....	41
7.3	RULE – ETHERNET CONNECTION MONITORING .....	42
7.4	RECOMMENDATION – INCORPORATE AUTO-MDIX.....	42
7.5	RULE – LABEL REQUIRED ON LXI DEVICES WITHOUT AUTO-MDIX.....	42
7.6	RULE – ENABLE AUTO-NEGOTIATION BY DEFAULT .....	43
7.6.1	Recommendation – Provide Override for Auto-Negotiation.....	43
7.7	RULE – MULTIPLE LAN INTERFACES .....	43
<b>8</b>	<b>IPV4 LAN CONFIGURATION.....</b>	<b>45</b>
8.1	RULE – TCP/IP, UDP, IPV4 NETWORK PROTOCOLS.....	45
8.1.1	Recommendation – LXI Devices should also support IPv6 to ensure long-term network compatibility.....	45
8.2	RULE – ICMP PING RESPONDER.....	45
8.3	RULE – ICMP PING RESPONDER ENABLED BY DEFAULT.....	45
8.4	RULE – PROVIDE WAY TO DISABLE ICMP PING RESPONDER .....	45
8.5	RECOMMENDATION – SUPPORT ICMP PING CLIENT .....	45
8.6	RULE – IP ADDRESS CONFIGURATION TECHNIQUES .....	46
8.6.1	RULE – Options for LAN configuration.....	47
8.6.2	Recommendation – 30-Second DHCP Timeout .....	47
8.6.3	RULE – Explicitly Request All Desired DHCP Parameters.....	47
8.6.4	Recommendation – Accept the First DHCP Offer Received.....	47
8.6.5	RULE – Do Not Require Additional DHCP Options for Normal Operations .....	47
8.6.6	RULE – Stop Using IP Address If DHCP Lease Not Renewed .....	48
8.6.7	RULE – Honor New DHCP Options at Lease Renewal .....	48
8.6.8	Recommendation – Provide Manual DNS IP Address Entry .....	48
8.6.9	Permission – User Configured Hosts File Allowed.....	49
8.6.10	RULE – Dynamic Link-Local Address .....	49
8.7	RULE – DUPLICATE IP ADDRESS DETECTION .....	50
8.8	RECOMMENDATION – CHECK NETWORK CONFIGURATION VALUES FOR VALIDITY .....	50
8.9	RECOMMENDATION – SINGLE HOSTNAME FOR ALL NAMING SERVICES .....	51
8.10	RULE – PROVIDE AN ERROR INDICATOR FOR LAN CONFIGURATION FAULTS .....	51
8.10.1	Permission – To show no fault if the LAN is inactive.....	53
8.11	RECOMMENDATION – SUPPORT DYNAMIC DNS HOSTNAME REGISTRATION .....	53
8.11.1	Recommendation – Provide User Control of Dynamic DNS Registration.....	54
8.12	RECOMMENDATION - PROVIDE DNS CLIENT .....	55
8.13	RULE – LAN CONFIGURATION INITIALIZE (LCI).....	55
8.13.1	Recommendation – LAN Configuration Initialize (LCI) Additional Settings.....	56
<b>9</b>	<b>WEB INTERFACE.....</b>	<b>57</b>
9.1	RULE – WEB PAGES USING W3C COMPLIANT BROWSERS .....	57
9.1.1	Deprecated RULE – Protocol and Port Number.....	57
9.1.2	Deprecated Recommendation – Web Server Root Document.....	57
9.1.3	Recommendation – Implement HTTP/2.0.....	57
9.1.4	RULE – HTTP Transport and Port Number.....	57

9.1.5	Permission – To still allow HTTP Connections .....	58
9.1.6	Recommendation – HTTPS X.509 Certificate Requirement.....	58
9.1.7	Rule – Alias for Welcome Page.....	58
9.2	RULE – WELCOME WEB PAGE DISPLAY ITEMS.....	58
9.2.1	RULE – LXI Device Address String on Welcome Page .....	59
9.2.2	Recommendation – Web Page Title .....	59
9.2.3	RULE – Actual Hostname Display.....	59
9.3	RULE – DEVICE IDENTIFICATION FUNCTIONALITY ON THE WEB PAGE.....	61
9.3.1	Permission – No password protection for device identification indicator .....	61
9.4	RULE – LAN AND SYNC CONFIGURATION LINKS ON THE WELCOME PAGE.....	61
9.4.1	Recommendation – Status Page Link on the Welcome Page .....	62
9.5	RULE – LAN CONFIGURATION WEB PAGE CONTENTS .....	62
9.5.1	Recommendation – Default Description for LXI Device .....	62
9.5.2	Recommendation – Auto-Negotiate Enable/Disable Through Web Page .....	62
9.5.3	Recommendation – Ping Enable/Disable Through Web Page.....	62
9.5.4	Permission – Other Information on the LAN Configuration Page .....	62
9.5.5	Permission – Disable Switch for LAN Configuration Page.....	62
9.5.6	Rule – mDNS Enable/Disable Through Web Page .....	62
9.5.7	Rule – Reverting Hostname to Factory Default.....	63
9.5.8	Rule – Reverting Device Description to Factory Default .....	63
9.6	RULE – SYNC CONFIGURATION WEB PAGE CONTENTS.....	64
9.7	DEPRECATED RECOMMENDATION – STATUS WEB PAGE CONTENTS.....	64
9.8	RULE – WEB PAGE PASSWORD PROTECTION .....	64
9.8.1	Revoked Permission – Blank password.....	64
9.9	RULE – LXI LOGO .....	64
9.10	RECOMMENDATION – LXI WEB INTERFACE EXAMPLE .....	64
9.11	RECOMMENDATION – LXI DEVICE CONTROL USING WEB PAGE .....	64
9.12	RECOMMENDATION – SOFTWARE/FIRMWARE UPGRADE USING WEB INTERFACE.....	65
9.13	RECOMMENDATION – LXI GLOSSARY.....	65
9.14	RULE – ALL URLS BEGINNING WITH “LXI” ARE RESERVED BY THE LXI CONSORTIUM.....	65
<b>10</b>	<b>LAN DISCOVERY AND IDENTIFICATION .....</b>	<b>66</b>
10.2	RULE – LXI API IDENTIFICATION METHODS.....	66
10.2.5	RULE – LXI Extended Function Elements .....	66
10.3	RULE – SUPPORT MDNS.....	66
10.3.1	RULE – Claiming Hostnames .....	67
10.3.2	Recommendation – Default mDNS Hostname .....	67
10.3.3	RULE – Dynamic DNS Update and mDNS Hostname .....	67
10.3.4	RULE – DHCP “Host Name” Option and mDNS Hostname.....	67
10.4	RULE – SUPPORT MDNS SERVICE DISCOVERY .....	67
10.4.1	RULE – Claiming Service Name.....	68
10.4.2	RULE – Single Service Instance Name for LXI Defined Services.....	68
10.4.3	Rule - Required Service Advertisements and TXT Record Keys.....	68
10.5	RULE – MDNS AND DNS-SD ENABLED BY DEFAULT .....	72
10.5.1	RULE – mDNS and DNS-SD Enabled by LAN Configuration Initialize (LCI) .....	72
10.5.2	Rule – Provide way to Disable mDNS and DNS-SD .....	72
10.6	RULE – MDNS NAME RESOLUTION .....	72
10.7	RULE – NONVOLATILE HOSTNAMES AND SERVICE NAMES.....	72
10.7.1	RULE – Hostname and Service Name Revert to Default.....	73
10.8	RULE – LINK CHANGES.....	73
<b>11</b>	<b>DOCUMENTATION .....</b>	<b>74</b>
11.1	RULE – FULL DOCUMENTATION ON IVI INTERFACE .....	74
11.2	RULE – REGISTRATION OF THE IVI DRIVER .....	74
11.3	RECOMMENDATION – DOCUMENTATION ON LXI DEVICE WEB PAGE.....	74

## *Notices*

**Notice of Rights** All rights reserved. This document is the property of the LXI Consortium. It may be reproduced, unaltered, in whole or in part, provided the LXI copyright notice is retained on every document page.

**Notice of Liability** The information contained in this document is subject to change without notice. “Preliminary” releases are for specification development and proof-of-concept testing and may not reflect the final “Released” specification.

The LXI Consortium, Inc. makes no warranty of any kind with regard to this material, including but not limited to, the implied warranties of merchantability and fitness for a particular purpose. The LXI Consortium, Inc. shall not be liable for errors or omissions contained herein or for incidental or consequential damages in connection with the furnishing, performance, or use of this material.

**LXI Standards Documents** are developed within the LXI Consortium and LXI Technical Working Groups sponsored by the LXI Consortium Board of Directors. The LXI Consortium develops its standards through a consensus development process modeled after the American National Standards Institute, which brings together volunteers representing varied viewpoints and interests to achieve the final product. Volunteers are not necessarily members of the Consortium and serve without compensation. While the LXI Consortium administers the process and establishes rules to promote fairness in the consensus development process, the LXI Consortium does not exhaustively evaluate, test, or verify the accuracy of any of the information contained in its standards.

Use of an LXI Consortium Standard is wholly voluntary. The LXI Consortium and its members disclaim liability for any personal injury, property or other damage, of any nature whatsoever, whether special, indirect, consequential, or compensatory, directly or indirectly resulting from the publication, use of, or reliance upon this, or any other LXI Consortium Standard document.

The LXI Consortium does not warrant that the use of the material contained herein is free from patent infringement. LXI Consortium Standards documents are supplied “as is”. The existence of an LXI Consortium Standard does not imply that there are no other ways to produce, test, measure, purchase, market, or provide other goods and services related to the scope of the LXI Consortium Standard. Furthermore, the viewpoint expressed at the time a standard is approved and issued is subject to change brought about through developments in the state of the art and comments received from users of the standard. Users are cautioned to check to determine that they have the latest edition of any LXI Consortium Standard.

In publishing and making this document available, the LXI Consortium is not suggesting or rendering professional or other services for, or on behalf of, any person or entity. Nor is the LXI Consortium undertaking to perform any duty owed by any other person or entity to another. Any person utilizing this, and any other LXI Consortium Standards document, should rely upon the advice of a competent professional in determining the exercise of reasonable care in any given circumstances.

This specification is the property of the LXI Consortium, a Delaware 501c3 corporation, for the use of its members.

**Interpretations** Occasionally questions may arise regarding the meaning of portions of standards as they relate to specific applications. When the need for interpretations is brought to the attention of LXI Consortium, the Consortium will initiate action to prepare appropriate responses. Since LXI Consortium Standards represent a consensus of concerned interests, it is important to ensure that any interpretation has also received the concurrence of a balance of interests. For this reason, LXI Consortium and the members of its working groups are not able to provide an instant response to interpretation requests except in those cases where the matter has previously received formal consideration. Requests for interpretations of this standard may be sent to [interpretations@lxistandard.org](mailto:interpretations@lxistandard.org) using the form “*Request for Interpretation of an*

*LXI Standard Document*". This document plus a list of interpretations to this standard are found on the LXI Consortium's Web site: <http://www.lxistandard.org>

**Legal Issues, Trademarks, Patents, and Licensing Policies.** These items are addressed specifically in the document "*LXI Consortium Trademark, Patent, and Licensing Policies*" found on the LXI Consortium's Web site: <http://www.lxistandard.org> .

**Conformance** The LXI Consortium draws attention to the document "*LXI Consortium Policy for Certifying Conformance to LXI Consortium Standards*" found on the LXI Consortium's Web site: <http://www.lxistandard.org> . That document specifies the procedures that must be followed to claim conformance with this standard.

**Comments for Revision** Comments for revision of LXI Consortium Standards are welcome from any interested party, regardless of membership affiliation with LXI Consortium. Suggestions for changes in documents should be in the form of a proposed change of text, together with appropriate supporting comments. Comments on standards should be addressed to:

Executive Director  
LXI Consortium  
[www.lxistandard.org](http://www.lxistandard.org)  
[ExecDir@lxistandard.org](mailto:ExecDir@lxistandard.org)

**LXI is a registered trademark of the LXI Consortium**

## Revision history

<b>Revision</b>	<b>Description</b>
1.6.1 Jan 18, 2024	<ul style="list-style-type: none"> <li>Fixed broken links in TOC</li> </ul>
1.6.1 Aug 10, 2023	<ul style="list-style-type: none"> <li>Rule 10.2 changed to refer to the API Extended Function. Note that as of this version of the specification, version 2.0 of the Identification XML Schema is required.</li> <li>Disallowed blank passwords.</li> <li>Other clarifications and editorial updates</li> </ul>
1.6 June 9, 2022	<ul style="list-style-type: none"> <li>10.4.3.10 Moved HiSLIP and VXI-11 service advertisements to their respective extended function documents</li> <li>Removed 10.4.3.11 and 10.4.3.12 and replaced with an observation that service advertisements can be done in any order</li> <li>Changed all references to “module” to “device”</li> <li>Section 9.1 has been completely revamped due to requiring HTTPS for the Web Server</li> <li>Incorporated Clarification document into this document</li> <li>Provide way to enable/disable mDNS</li> <li>Updated IPv4 RFC’s</li> <li>Added a table in the Conformance section showing all the Extended Function versions that are part of this LXI 1.6 release</li> <li>Rule 10.2 – changed URL to the Identification schema showing port 80 to port being an optional parameter</li> <li>Deleted observation in Rule 9.1.7 as not providing any additional information</li> <li>Updated the observation in Rule 10.4.3 to suggest what port should be advertised when announcing HTTP and LXI mDNS services.</li> <li>Permission <a href="#">2.5.1.4.2</a> - Power Indication for Devices with a Front Panel added back. It was removed in LXI 1.5</li> </ul>
1.5.01 March 14, 2017	Official date change after review.
1.5.01 February 19, 2017	Minor changes to Rules 1.4.5 and 1.4.6 to add 2016 year, which is consistent with the naming of this version of the LXI Standard. Clarification of LAN status indicator by adding Observation to Rule 2.5.2.
1.5 Version	Initial Release November 8, 2016

# 1 Overview

## 1.1 Introduction

This standard has been written and is controlled by the members of LXI Consortium, a not-for-profit organization created for the development and promotion of a LAN (Ethernet) based standard for instrumentation and related peripheral devices. LXI is an acronym for LAN eXtensions for Instrumentation. The LXI specification details the technical requirements of LXI Devices using Ethernet as the primary communications means between devices.

## 1.2 Purpose and Scope of this Document

### 1.2.1 Purpose

Key objectives in the development of this standard for test and measurement instrumentation include:

1. Unambiguous communication among LXI Devices
2. Decreasing the cost of test system software development by the use of industry-standard protocols and interfaces
3. Provision of a standardized trigger and synchronization mechanism between LXI Devices
4. Increasing system performance by using high-speed, Ethernet protocols
5. Taking advantage of the simplicity of physical Ethernet connectivity.

### 1.2.2 Scope

This document defines a set of **RULES** and **RECOMMENDATIONS** for constructing a conformant LXI Device. Whenever possible these specifications use existing standards.

The standard consists of two categories:

1. **LXI Device Specification.** This is the content of this document. The LXI Device Specification covers Rules, Recommendations, etc. that are required by all LXI conformant devices.
2. **LXI Extended Functions.** The LXI Extended Functions represent optional features added to an LXI Device. If added, they must conform to the Rules presented in the external LXI Extended Function specifications (external to this document).

Although this specification focusses on the core requirements of an LXI conformant device, it does refer to some LXI Extended Function requirements. For example, there are common rules between some Extended Functions, and those rules are retained in this document. There are also Web pages with information required for all LXI Devices that also present information about Extended Functions.



### 1.2.3 Changes from previous LXI Device Specifications

The LXI Device Specification originally combined requirements for LXI Extended Functions into three class categories representing Class C (required by all LXI Devices) and then adding Classes A and B, which included hardware triggering, time stamping, synchronization, device to device communication, and other advanced features. Rather than provide Classes, the LXI Device Specification focusses on all common or core requirements for all LXI Devices, and the differentiating features between of Class A and Class B are now represented as optional Extended Functions presented in external documents

Given the transition to separating LXI Extended Functions from the LXI Device Specification, it became imperative to maintain Rule, Recommendation, and Section numbering to minimize changes to existing external documentation, conformance testing, and other published references to the LXI Device Specification. Therefore, this document retains all Rule, Recommendation, and Section numbering of the previous specifications. Content specific to LXI Extended Functions move to external specifications, but section numbers remain in this document as placeholder to maintain numbering. The newly created LXI Extended Function documents retain the original section numbers, which maintains the original Rule and Recommendation numbers.

For example, the previous LXI Device Specification contained the LXI Device Wired Trigger Bus requirements, which encompassed all of Section 5 in the original specification. That feature is an advanced capability that is now an LXI Extended Function. Therefore, all of Section 5 moves from this document to Section 5 in a new external specification document called ***LXI Device Wired Trigger Bus Extended Function***. This document retains the original Section 5 heading but with a pointer to the new location of the requirements.

Other advanced features moving from the original LXI Device Specification include: LXI Event Messaging, LXI Clock Synchronization, LXI Timestamped Data, and LXI Event Logs. Similar content transfer occurs for these functions, where in each case Section number preservation occurs in the new documents with Section number preservation and reference pointers added to this document. Common rules between some of the above Extended Functions are retained in their original location within this document to avoid replicating the same rules in multiple documents.

## 1.3 Definition of Terms

This document contains both normative and informative material. Unless stated otherwise the material in this document shall be considered normative.

**NORMATIVE:** Normative material shall be considered in determining whether an LXI Device is conformant to this standard. Any section or subsection designated as a **RULE** or **PERMISSION** is normative.

**INFORMATIVE:** Informative material is explanatory and is not considered in determining the conformance of an LXI Device. Any section or subsection designated as **RECOMMENDATION** or **OBSERVATION** is informative. Unless otherwise noted, examples are informative.

**RULE:** Rules shall be followed to ensure compatibility for LAN-based devices. A rule is characterized by the use of the words **SHALL** and **SHALL NOT**.

**RECOMMENDATION:** Recommendations consist of advice to implementers that will affect the usability of the final device. Discussions of particular hardware to enhance throughput would fall under a recommendation. These should be followed to avoid problems and to obtain optimum performance.

**PERMISSION:** Permissions are included to clarify the areas of the specification that are not specifically prohibited. Permissions reassure the reader that a certain approach is acceptable and will cause no problems. The word **MAY** is reserved for indicating permissions.

**OBSERVATION:** Observations spell out implications of rules and bring attention to things that might otherwise be overlooked. They also give the rationale behind certain rules, so that the reader understands why the rule must be followed. Any text that appears without heading should be considered as description of the specification.

### 1.3.1 Use of the Term *default*

When the term *default* is used in this document to refer to a setting, it refers to the value of the setting when the device is shipped by the vendor, or after the operator performs a reset on the device that entirely removes the previous configuration of the device.

The value of the setting after an LCI is performed is referred to as the LCI value of the setting.

## 1.4 Applicable Standards and Documents

The following referenced documents are indispensable for the application of this document (i.e., they must be understood and used). For dated references, only the edition cited applies. For undated references, the latest edition of the referenced document (including any amendments or corrigenda) applies. These applicable Standards and Documents include references for material used in both the LXI Device Specification and for LXI Extended Functions, since there is significant overlap in material in some case.

### 1.4.1 **RULE – Applicable Version of Documents**

For dated references, only the edition cited (including any amendments or corrigenda) shall be used in conjunction with this standard.

Unless otherwise stated, for undated references, the edition of the referenced document (including any amendments or corrigenda) applicable at the date of certification of the LXI Device to this standard shall be used in conjunction with this standard.

### 1.4.2 Standards and Specifications

#### 1.4.2.1 IEEE<sup>1,2</sup>, and ANSI/TIA/EIA<sup>3</sup> Standards

ANSI/TIA/EIA-568-B.2, Commercial Building Telecommunications Cabling Standard - Part 2: Balanced Twisted Pair Cabling Components

ANSI/TIA/EIA-899, Electrical Characteristics of Multipoint-Low-Voltage Differential Signaling (M-LVDS) Interface Circuits for Multipoint Data Interchange

IEEE Std 802.3™ IEEE Standard for Information Technology—Telecommunications and information exchange between systems—Local and metropolitan area networks—Specific requirements—Part 3: Carrier Sense Multiple Access with Collision Detection (CSMA/CD) access method and physical layer specifications

Section 1: Type 10 BASE-T

Section 2: Type 100 BASE-TX

---

<sup>1</sup> The IEEE standards or products referred to in this section are trademarks of the Institute of Electrical and Electronics Engineers, Inc.

<sup>2</sup> IEEE publications are available from the Institute of Electrical and Electronics Engineers, 445 Hoes Lane, Piscataway, NJ 08854, USA IEEE 802 standards are also available for download at <http://standards.ieee.org/getieee802>

<sup>3</sup> EIA documents are available from the Telecommunications Industry Association at <http://www.tiaonline.org/>

### Section 3: Type 1000 BASE-T

IEEE Std 802.3af, Specified in IEEE 802.3-2005 Section 2, Clause 33

IEEE Std 1588™ IEEE Standard for a Precision Clock Synchronization Protocol for Networked Measurement and Control Systems

#### 1.4.2.2 IETF RFC Documents<sup>4</sup>

IETF RFC 768, “User Datagram Protocol”, J. Postel, August 1980, (Status: Standards track)

IETF RFC 791, “Internet Protocol,” Information Science Institute, University of Southern California, September 1981, (Status: Standards track)

IETF RFC 793, “Transmission Control Protocol,” Information Science Institute, University of Southern California, September 1981, (Status: Standards track)

IETF RFC 1035, “Domain Names- Implementation and Specification”, P. Mockapetris, November 1987, (Status: Standards track)

IETF RFC 4248, “The telnet URI Scheme,” P. Hoffman, October 2005 (Obsoletes RFC 1738) (Status: Standards track) IETF RFC 4266, “The gopher URI Scheme,” P. Hoffman, November 2005 (Obsoletes RFC 1738) (Status: Standards track)

IETF RFC 2131, “Dynamic Host Configuration Protocol,” R. Droms, March 1997 (Obsoletes RFC1541) (Status: Standards track)

IETF RFC 2132, “DHCP Options and BOOTP Vendor Extensions,” S. Alexander, R. Droms, March 1997 (Obsoletes RFC1533) (Status: Standards track)

IETF RFC 7230, “Hypertext Transfer Protocol (HTTP/1.1): Message Syntax and Routing,” R. Fielding, Ed.Adobe, J. Reschke, Ed. Greenbytes, June 2014, (Obsoletes RFC2616) (Status: Standards track)

IETF RFC 7231, “Hypertext Transfer Protocol (HTTP/1.1): Semantics and Content,” R. Fielding, Ed.Adobe, J. Reschke, Ed. Greenbytes, June 2014, (Obsoletes RFC2616) (Status: Standards track)

IETF RFC 7232, “Hypertext Transfer Protocol (HTTP/1.1): Range Requests,” R. Fielding, Ed.Adobe, J. Reschke, Ed. Greenbytes, June 2014, (Obsoletes RFC2616) (Status: Standards track)

IETF RFC 7233, “Hypertext Transfer Protocol (HTTP/1.1): Message Syntax and Routing,” R. Fielding, Ed.Adobe, Y. Lafon, J. Reschke, Ed. Greenbytes, June 2014, (Obsoletes RFC2616) (Status: Standards track)

IETF RFC 7234, “Hypertext Transfer Protocol (HTTP/1.1): Caching,” R. Fielding, Ed.Adobe, M. Nottingham, Ed. Akamai, J. Reschke, Ed. Greenbytes, June 2014, (Obsoletes RFC2616) (Status: Standards track)

IETF RFC 7235, “Hypertext Transfer Protocol (HTTP/1.1): Authentication,” R. Fielding, Ed.Adobe, J. Reschke, Ed. Greenbytes, June 2014, (Obsoletes RFC2616) (Status: Standards track)

IETF RFC 3927, “Dynamic Configuration of IPv4 Link-Local Addresses,” S. Cheshire, B. Aboba, E. Guttman, May 2005 (Status: Proposed Standard)

Note: These RFCs are current as of the release of this specification. Check the RFC to see if has been obsoleted by another one.

---

<sup>4</sup> IETF publications are available from the Internet Engineering Task Force on the World Wide Web at <http://www.ietf.org/rfc.html>

### 1.4.2.3 LXI Consortium Documents

The LXI Consortium maintains the *Guide to LXI Documentation* that lists all the current LXI material including LXI standards and other documents. The *Guide to LXI Documentation* is available on the LXI web site.

### 1.4.2.4 Trade Association Standards<sup>5,6,7</sup>

IVI-3.1, “Driver Architecture Specification”

IVI-3.15, “IviLxiSync Specification”

IVI VISA specifications

VXI 11 Revision (7/17/1995), “TCP/IP Instrument Protocol Specification”

The IVI and VPP specifications can be found on the IVI Foundation See the website for current versions of these specifications.

### 1.4.3 LXI Consortium Supplementary Documents<sup>8</sup>

LXI maintains additional documents and requirements. Implementors should be familiar with the following:

“[LXI Consortium Policy for Certifying Conformance to LXI Consortium Standards](#)”

“[LXI Consortium Trademark, and Logo Usage Guidelines](#)”

“[Recommendations for LXI systems containing devices supporting different versions of IEEE 1588](#)”

“[LXI Wired Trigger Bus Cable And Terminator Specifications](#)”

### 1.4.4 LXI Device Specification and Extended Functions

#### 1.4.4.1 General Description

The LXI Standard consists of a common or core capability referred to as the LXI Device Specification, and all LXI Devices must conform to these common or core requirements. In addition, the LXI Standard provides for optional Extended Functions documented in separate documents.

#### **LXI Device Specification**

This document provides a standardized LAN, web browser, and IVI Driver interface that is conformant with the LXI Standard. This set of common or core requirements causes consistent behavior of all LXI conformant devices when connecting to LAN. Test systems built with LXI Devices are much easier to configure and program.

This standard does not require any physical size for an LXI Device. However, it specifies some physical specifications for electrical standards and status indication.

---

<sup>5</sup> IVI specifications are available from the IVI Foundation at <https://www.ivifoundation.org>

<sup>6</sup> LXI Standards are available from the LXI Consortium at <https://www.lxistandard.org>

<sup>7</sup> VXI-11 specifications are available from the VXI Bus Consortium at <http://www.vxibus.org/>

<sup>8</sup> LXI supplementary documents are available from the LXI Consortium at <https://www.lxistandard.org>

## **LXI Extended Functions**

Extended Functions are external documents. Each Extended Function document has sections numbered as extensions to the LXI Device Specification, but the documents are separate to simplify maintenance of the standard and to add new Extended Functions without altering the LXI Device Specification. The [Guide to LXI Documentation](#) identifies LXI Extended Function documents.

#### 1.4.4.2 **RULE – Conformance Requirements**

The rules in this document define the conformance requirements for the LXI Device Specification. All LXI Devices shall conform to the rules in this specification. Implementers of LXI Devices should also consider the recommendations, observations, and permissions cited in those sections.

In addition to this specification all LXI Devices that claim compliance with any LXI Extended Function shall implement at least the revision of any implemented extended functions in the following list:

- LXI API Extended Function (Revision 1.1)
- LXI Clock Synchronization Extended Function (Revision 1.1)
- LXI Device Specification (Revision 1.6.1)
- LXI Event Log Extended Function (Revision 1.0)
- LXI Event Messaging Extended Function (Revision 1.1)
- LXI Example and Reference Material (Revision 1.2)
- LXI HiSLIP Extended Function (Revision 1.4)
- LXI IEEE 1588 Profile (Revision 1.0)
- LXI IPv6 Extended Function (Revision 2.1)
- LXI Security Extended Function (Revision 1.1)
- LXI Timestamped Data Extended Function (Revision 1.1)
- LXI VXI-11 LAN Discovery and Identification Extended Function (Revision 1.1)
- LXI Wired Trigger Bus Extended Function (Revision 1.1)
- LXI Wired Trigger Bus Cable and Terminator Specification (Revision 2.0)

Devices are not required to implement any extended function however if devices do, they shall conform to all the requirements in the extended function specification.

##### 1.4.4.2.1 **RULE – LXI Device Specification Conformance Requirements**

All LXI Devices shall implement and conform to all common or core rules and additional rules associated with various other standards (e.g. IVD). Where noted, some rules are common to and *only* applicable to some Extended Functions. These are found in Sections 3, 4, 5, 9, and 10.

#### 1.4.5 **RULE – Functional Declaration**

Manufacturers of LXI Devices shall clearly declare that a device is LXI Device Specification conformant and shall declare any implemented LXI Extended Functions within the data sheet and supporting documentation. The Functional Declaration shall be declared as follows:

- 1.6 LXI Device Specification 2023 (if the LXI Device is conformant to Rule 1.4.4.2.1)

The only other declarations permitted are for other LXI Extended Functions approved by the LXI Consortium as defined in separate documents and described in the [Guide to LXI Documentation](#)

#### 1.4.6 **RULE – Web Indication of Functional Declaration**

The Functional Declaration shall be declared on the web interface and is the definitive source for Functional Declaration information for an LXI Device. See section 9.2, *RULE – Welcome Web Page Display Items* for additional requirements regarding this page.

It shall include:

**LXI Version:**

1.6 LXI Device Specification 2023

**LXI Extended Functions:**

List of supported LXI Extended Functions using the extended function names as defined in each LXI Extended Function specification (example: LXI HiSLIP). The web page shall list all the LXI Extended Functions supported.

**Observation**

If the Functional Declaration of an LXI Device is upgraded by a software download or hardware modification, the web interface must be updated to reflect the new functionality.

**1.4.7 RULE – Terms Using the LXI Trademark**

The LXI Trademark or registered name, LXI, shall be used to describe the LXI Device and any LXI Extended Function.

As further LXI Extended Functions are created, the specifications for those Extended Function specification will contain a description of the terms to be used.

## 2 LXI Physical Specifications

### 2.1 Introduction

The LXI Physical Specification section covers type and location of connectors, switches, status indicators, and related components. These specified components and their behavior creates a common user interface for all LXI Devices.

### 2.4 Electrical Standards

The Electrical Standards define the type and location of all connectors, switches, indicators, and related components.

#### 2.4.5 LAN Configuration Initialize (LCI)

##### 2.4.5.1 RULE – LCI Mechanism

LXI Devices shall provide an LCI Mechanism that, when activated, places its network settings in a defined state. The functions performed by this mechanism are defined in Section 8.13.

##### **Observation**

It is possible to improperly configure the network settings of a device, potentially rendering it unable to communicate with any hosts. Additionally, the settings on a box could simply be forgotten.

##### 2.4.5.2 RULE – LXI Devices Without a Front-Panel Manual Data-Entry Method

LXI Devices shall provide an LCI mechanism by either:

- a) A separate recessed mechanical LCI mechanism on the rear or front of the device (rear is preferred).
- b) A soft LCI mechanism through a permanently attached user interface (e.g., a front panel, monitor, mouse, keyboard, et cetera) that does not use the LAN as the interface.

##### **Observation**

The LCI and LAN status indicators in Rules 2.5.2 to 2.5.2.2) are considered to be important features of the LXI Standard and are a notable extra feature required of LXI Devices which may not be on simple LAN products. The Consortium believes it is important these are always available to a user without having to search for additional devices to provide access to them. In Consortium discussions it has been accepted that a product such as a USB dongle with a tether to the LXI Device inserted in a USB port would be considered permanent, even though a user might at some stage remove the tether, provided the tethered dongle is supplied with the LXI Device. The dongle could include both the status indicator and the LCI button.

##### 2.4.5.2.1 Recommendation – Not Using LCI Mechanism for Other Purposes

The mechanism (especially that described in RULE 2.4.5.2) that invokes the LAN Configuration Initialization should not be used for any other function.



If this mechanism is also used for something else, such as instrument reset, the two ways to actuate it should be distinct enough so that it is difficult for a user to invoke the wrong one, and the mechanism (e.g., “LAN RESET” Button) should be labeled to show it performs multiple functions.

#### **2.4.5.3 RULE – LCI Mechanism Protection**

The LCI Mechanism shall be protected by a time-delay, user query, or mechanical protection feature designed to prevent inadvertent operation.

#### **2.4.5.4 Recommendation – LCI Mechanism Location**

The LCI should be located on the rear panel of the device in the same general area as the power switch, if present.

##### **2.4.5.4.1 Permission – LCI Mechanism Location**

To address market specific requirements, the LCI may be located on the front panel of the device.

#### **2.4.5.5 Recommendation – LCI Mechanism Label**

The LCI Mechanism should be labeled “LAN RST” or “LAN RESET”.

##### **2.4.5.5.1 Permission – LXI Devices with a Front Panel**

For devices with a front-panel manual data-entry method such as a keypad or touch panel user interface, the LCI functions may be executed by a single keystroke or a sequence of keystrokes.

##### **2.4.5.5.2 Permission – LCI Mechanism Lockout**

For LXI Devices intended for deployment in critical conditions, manufacturers can include an LCI Mechanism Lockout function in the form of a protected or internal switch or jumper that prevents all reset functions from being accessed.

### **2.4.9 LAN Connectors**

This section deals with physical IEEE 802.3 LAN connectors.

#### **2.4.9.1 RULE – IEEE 802.3**

Physical Ethernet connections shall be IEEE 802.3 compliant.

#### **2.4.9.3 Recommendation – RJ-45 Connector**

RJ-45 connectors should be used unless technical reasons require otherwise.

#### **2.4.9.4 Recommendation – M12 Style Connectors**

If RJ-45 style connectors are not acceptable, M12 style connectors should be considered.

#### ***Observation – M12 Style Connectors***

M12 style connectors are commonly used for industrial Ethernet applications in both 4-pin and 8-pin configurations.
---

## 2.5 Electrical Standards – Status Indicators

LXI Devices have LED status indicators for Power, LAN, etc.

### Observation

The following table summarizes the recommendations for the color, location, orientation, and labeling of the status indicators:

	<b>Power Indicator</b>	<b>LAN Status Indicator</b>	<b>IEEE 1588 Clock Status Indicator</b>
LED Color(s)	Bi-Color (Orange/Green)	Bi-Color (Red/Green)	Bi-Color (Red/Green)
Front panel location	Lower left-hand corner of the front panel  Power	Next to and to the right of the Power Indicator  Power LAN	Next to and to the right of the LAN Status Indicator  Power LAN 1588
Horizontal Orientation  Note: The status indicators are ordered in the LXI Device turn-on sequence.	Power LAN 1588 (Left LED)  LXI Device turn-on sequence: First, enable power.	Power LAN 1588 (Middle LED)  LXI Device turn-on sequence: Second, acquire LAN IP Configuration.	Power LAN 1588 (Right LED)  LXI Device turn-on sequence: Third, acquire IEEE 1588 clock.
Vertical Orientation  Note: The status indicators are ordered in the LXI Device turn-on sequence.	1588  LAN  Power (Bottom LED)  LXI Device turn-on sequence: First, enable power.	1588  LAN  Power (Middle LED)  LXI Device turn-on sequence: Second, acquire LAN IP Configuration.	1588  LAN  Power (Top LED)  LXI Device turn-on sequence: Third, acquire IEEE 1588 clock.
Labeling [1]	Universal power symbol, or PWR, or POWER	LAN	1588

[1] The location of labels is not specified. They are left to the discretion of each vendor.

## 2.5.1 Power Indicator

### 2.5.1.1 RULE – Power Indicator

A Power Indicator shall be provided on the front panel of the device.

### 2.5.1.2 Recommendation – Power Indicator Color

Some LXI Devices may keep the power supply in stand-by mode while the device itself is turned off. From a safety perspective, it is recommended this state be identified by the power status indicator. For LXI Devices that utilize a Standby Power state, the Power indicator should be a tri-state bi-color (Orange/Green) LED whose states are identified as follows:

<b>State</b>	<b>Status</b>	<b>Interpretation</b>
OFF No illumination	No Power	No power is applied.
STANDBY Solid Orange, steady illumination	Standby Power	The Standby state is used for safety purposes by those devices that keep the power supply hot while the device itself is turned off.
ON Solid Green, steady illumination	Power is ON	Power is applied.

For LXI Devices that do not utilize a Standby Power state, the Power indicator should be a single color (Green) LED whose states are identified as follows:

<b>State</b>	<b>Status</b>	<b>Interpretation</b>
OFF No illumination	No Power	No power is applied.
ON Solid Green, steady illumination	Power is ON	Power is applied.

#### 2.5.1.4.2 Permission – Power Indication for Devices with a Front Panel

For devices with a front panel, the equivalent Power Indicator may be presented in a manner consistent with the design and capabilities of the front panel, such as a marked switch or an integrated display.

The use of symbols on a display, instead of LED status indicators, is permitted. Such indicators do not have to be permanently visible but could be accessed via some display navigation method.

### 2.5.2 LAN Status Indicator

The LAN Status Indicator fulfills different functions from the standard LAN activity indicator often built into RJ-45 LAN connectors. The LAN status indicator should be a bi-color (Red/Green) LED providing an indication of three states: normal operation, fault indication and device identification.

#### 2.5.2.1 RULE – LAN Status Indicator

A LAN Status Indicator shall be provided on the device front panel.

#### **Observation – Clarification of Intent of RULE 2.5.2.1**

Any reasonable method of displaying the LAN Status Indicator on the device front panel will be accepted, including the use of alpha-numeric and graphical displays. The recommendations in 2.5.2.2 and 2.5.2.2.1 are suggestions on how it can be implemented in designs using LED's that has been commonly used. Further examples can be found in the [LXI Example and Reference Material](#) document.

#### 2.5.2.2 Recommendation – LAN Status Indicator Color and States

The LAN Status Indicator should be a bicolor (Red/Green) LED whose states are identified as follows:

State	Status	Interpretation
On – Solid Green, steady illumination	Normal Operation	Normal Operation
On – Flashing Green	Device Identify	A Device Identification command was activated on the device's web pages or driver interface. The status indicator shall continue to flash green until told to do otherwise (this is not a one-time flash, rather it is toggled on and off by a web interface control)

On - Solid Red, steady illumination	LAN Fault	See section <a href="#">RULE 8.10</a>
-------------------------------------	-----------	---------------------------------------

**Observation – Clarification of Intent of Recommendation 2.5.2.2**

Rule 2.5.2 and Recommendation 2.5.2.2 say the LAN Status Indicator should be a red and green LED. The LXI Consortium does not require these two colors but suggests using a green LED to indicate a healthy LAN status.

**2.5.2.2.1 Permission – LAN Status Indicator Color and States**

If an LXI Device’s design precludes the use of a bi-color LED, the use of a single Green colored LED is permitted. In this situation, the LAN status states should be interpreted as follows.

State	Status	Interpretation
On – Solid Green, steady illumination	Normal Operation	Normal Operation
On – Flashing Green	Device Identify	A Device Identification command was received over the LAN. The status indicator shall continue to flash green until told to do otherwise (this is not a one-time flash, rather it is toggled on and off by a web interface control)
Off	LAN Fault	See Section <a href="#">RULE 8.10</a> for LAN Fault Conditions

**2.5.2.3 Permission – LAN Status Indicator Location**

If an LXI Device’s design precludes placing the LAN Status Indicator in the recommended front panel location, it may be placed on the rear panel.

**2.5.2.4 Deprecated Recommendation – LAN Status Indicator Orientation**

**2.5.2.5 Recommendation – LAN Status Indicator Label**

The LAN Status Indicator should be labeled *LAN*.

**2.6 LXI Device and Documentation Labeling Requirements**

Devices are required to have either a front panel label or an electronic label presented through the device interface.

#### 2.6.1.1 **RULE – Front Panel Labeling Requirements**

There shall be an LXI Logo on the front of the device. The logo shall conform to the specifications in the document [\*LXI Consortium Trademark, Patent and Licensing Policies\*](#).

#### 2.6.1.2 **Permission – Electronic Front Panel Labels**

Electronic labels are acceptable instead of a painted or other label on the front of the device. The electronic labels shall conform to the specifications in the document [\*LXI Consortium Trademark, Patent and Licensing Policies\*](#).

## 3 LXI Device Synchronization and Events

### 3.1 Introduction

Rules, Recommendations, etc. within this section are common to one or more of the following LXI Extended Functions:

- *LXI Event Messaging*
- *LXI Wired Trigger Bus*
- *LXI Clock Synchronization*
- *LXI Event Logging*

The triggering and synchronization capabilities of an LXI Device enable system integrators to:

- *Control the sequencing of states within an LXI Device or across the system*
- *Control the timing of issuing and handling of local and system events*
- *Order or correlate measurement data and significant events based on timestamps*

LXI allows three modes of inter-device LXI Event communication:

- *Via driver commands from a controller (or any other device that can function as a controller) to an LXI Device via the LAN*
- *Direct device-to-device messages via LXI Event Messages*
- *Hardware trigger lines from device to device*

LXI allows five modes of triggering:

- *Driver command-based: A driver interface on the controlling computer is used to directly transmit a command to an LXI Device.*
- *Direct LXI Event Messaging: An LXI Event message containing triggering information (including a timestamp) is sent directly from one device to another via the LAN (see Section 4 of the LXI Event Messaging Extended Function document).*
- *Time-based events: An IEEE 1588-based time trigger is set and executed internally in an LXI Device. (see Section 5 of the LXI Wired Trigger Bus Extended Function document).*
- *LXI Wired Trigger Bus-based: AN LXI Device function is triggered via a voltage on the LXI Wired Trigger Bus (see Section 3 of the LXI Clock Synchronization Extended Function document).*
- *Optional vendor-specific hardware triggers*

## 3.5 LXI Event Handling

### 3.5.1 RULE – Measurement-related Functions Initiated by LXI Events

Any measurement-related function executable via the controller-based driver (e.g., IVI) shall also be executable from within the LXI Device. These functions shall be executable by the local LXI Device based on any of the following LXI Event mechanisms implemented in the LXI Device:

- LXI Event Messages from other system devices, Section 3.3 of the LXI Event Messaging Extended Function
- Internal time-based events, Section 3.2.10 of the LXI Clock Synchronization Extended Function
- LXI Wired Trigger Bus, Section 5 of the LXI Wired Trigger Bus Extended Function.

(Note: The term “measurement-related” does not refer to basic LXI Device configuration. For instance, setting the frequency of a source is a “measurement-related function,” while setting the IP address of an LXI Device is not.)

#### 3.5.1.1 Recommendation – Include Conventional Triggers

Conventional hard-wired trigger inputs may be included in the acceptable LXI Events subject to Rule 3.5.1.

#### ***Observation – Clarification of Intent of RULE 3.5.1***

Rule 3.5.1 is intended to allow time-scheduled execution and inter-device coordination of execution without involving the controller. However, the term “executable by the local LXI Device” does not imply that an instrument command (e.g., a SCPI command) must be embedded in the LXI Event Message that is sent from one device to another. As described in Section 4 of the LXI Event Message Extended Function document, these messages contain an Event ID and a timestamp. Prior to receipt of these messages, the controller must program the instrument’s response. Rule 3.5.1 is intended to ensure that all of the relevant functions of an instrument are available for responding to direct LXI Event Messages and other LXI Event mechanisms.

Likewise, Rule 3.5.1 does not require that the LXI Device’s firmware must have an API that is identical to the drivers. It is required that trigger-related functionality be available in both the driver and the firmware, but there is no requirement that this functionality be presented to the user in the same format.

Nothing in this observation prohibits an LXI Device designer from implementing the LXI Devices’ response to an LXI Event using hardware rather than firmware.

Furthermore, the term “trigger-related functions” refers to those actions that the controller has configured or set up in advance to be accomplished upon receipt of a trigger. It does not refer to the configuration or setup activity itself. However, see the following Recommendation.



### **Observation – Clarification of Intent of Recommendation 3.5.1.1**

The intent of Recommendation 3.5.1.1 is to supply system integrators with the greatest possible flexibility in implementation of triggering. It is recognized that certain applications may require triggering in hardware that is not feasible in software (e.g., a hardware trigger that repeats at a 10 MHz rate may be impractical to handle in software). However, implementation of Recommendation 3.5.1.1 is important to achieve interoperability between instruments from various vendors. Although there are situations where it is not possible, designers should consider Recommendation 3.5.1.1 to be a rule unless serious technical obstacles exist.

### **Observation – Controller Need Not Implement IEEE 1588**

The controlling computer does not have to implement IEEE 1588. If a controller needs the current IEEE 1588 time in order to generate an LXI Event Message or for other purposes, it can always request the current time from any device participating in IEEE 1588 provided that the controller recognizes that the accuracy of this time will be severely degraded (perhaps by many milliseconds) by message and processing latencies.

### **3.5.1.2 Recommendation – Allow Multiple Actions from a Single Trigger**

LXI Devices should provide for the execution of multiple events or configuration changes to be initiated by a single LXI Event, programmable by the user.

### **Observation – Downloading Executable Code to LXI Devices**

Recommendation 3.4 in the LXI Event Messaging Extended Function infers the preloading of time-based or procedural programs of actions to be taken based on a single LXI Event. This allows system-wide tradeoff between LXI Device configurations prior to the start of a test and run-time configuration involving the controller during a test. However, the LXI specification does not mandate any particular method for downloading such programs into an LXI Device, whether these programs are pre-installed in the LXI Device or whether they are implemented in software or hardware. This is left to the vendor's discretion.

### **3.5.1.3 RULE – Specify Trigger Response Times**

For each triggered function configurable under rule 3.5.1 that is implemented in an LXI Device, the published specification shall include the time that it takes to respond to each of the possible triggering methods. This information shall include the minimum, maximum, and typical response times (exclusive of LAN latencies and other timing effects that are external to the LXI Device itself). For response times that are probabilistic in nature, the minimum and maximum response times shall be specified with a 95% confidence. If the response time is unknown or cannot be determined, the manufacturers shall explicitly state that the time is unknown. This information shall be available as a part of the documentation that accompanies each LXI Device (whether printed or electronic).

#### 3.5.1.3.1 Recommendation – Trigger Response Times Available via Driver

The information provided for in 3.5.1.3 should be available on the controller via the driver interface.

#### 3.5.1.3.2 Recommendation – LXI Events Executable via Driver Call

Events under rule 3.5.1 and recommendation 3.5.1.1 should also be accessible via the driver interface on the controller.

#### ***Observation – Likely Implementation for Trigger Functionality***

Triggering based on driver commands is usually implemented in firmware. Device-to-device LXI Event Message-based triggers will likely be implemented by a local event manager but may also use hardware techniques (e.g., LAN “packet sniffers”) to reduce latency. Time-based triggers will usually use hardware techniques configurable by the event manager in the LXI Device. LXI Wired Trigger Bus and vendor-specific hardware trigger will naturally be based in hardware.

#### ***Observation – Trigger Schemes Can Be Mixed***

Rule 3.5.1 and recommendation 3.5.1.1 allow system integrators to select or combine trigger schemes to meet the overall coordination requirements of the system.

### 3.5.2 Recommendation – Trigger Outputs Can Be Transmitted by Any Method

Any LXI Device capable of detecting an LXI Event that can be used as a trigger should be configurable to communicate this trigger event to other devices by LXI Event Message (using the LXI Event Message format defined in Section 4 of the LXI Event Message Extended Function document), LXI Wired Trigger Bus, or optional vendor specific hardware.

#### ***Observation – Clarification of Intent of Recommendation 3.5.2***

The intent of Recommendation 3.5.2 is to supply system integrators with the greatest possible flexibility in implementation of triggering. It is recognized that certain applications may require triggering in hardware that is not feasible in software (e.g., a hardware trigger that repeats at a 10 MHz rate may be impractical to handle in software). However, implementation of Recommendation 3.5.2 is important to achieve interoperability between instruments from various vendors. Although there are situations in which it is not possible, designers should consider Recommendation 3.5.2 to be a rule unless serious technical obstacles exist.

### 3.5.2.1 **RULE – Specify Trigger Output Response Times**

If Recommendation 3.5.2 is implemented, for each LXI Event that can cause a trigger the published specification shall include the time it takes the LXI Device to respond to the event and transmit a trigger by each of the possible triggering methods. This information shall include the minimum, maximum, and typical response times. For response times that are probabilistic in nature, the minimum and maximum response times shall be specified with a 95% confidence. If the response time is unknown or cannot be determined, the manufacturers shall explicitly state that the time is unknown. This information shall be available as a part of the documentation that accompanies each LXI Device (whether printed or electronic).

### 3.5.2.2 **Recommendation – Trigger Output Response Times Available via Driver**

The information provided for in Rule 3.5.2.1 should be available on the controller via the driver interface.

### 3.5.2.3 **Recommendation – Events Available via Driver Call**

Events under Recommendation 3.5.2 should also be accessible via the driver interface on the controller.

#### ***Observation – Possible Trigger Output Implementations***

Recommendation 3.5.2 implies that internal events in an LXI Device must interrupt the LXI Device's processor so that the processor can transmit LXI Event Messages to other devices if the LXI Device has been programmed to do so. It is also possible and permissible for a device to implement generation and communication of a trigger LXI Event at much lower levels in the protocol stack than at the application or interrupt level to reduce time delays and latency.

## 3.7 **RULE– Internal Log File for Events**

All LXI Devices capable of acting on or generating LXI Events shall be configurable to record a timestamp and event identifier for all transmitted and received LXI Event Messages (TCP unicast and UDP multicast) in an internal LXI Event Log. This LXI Event Log shall be accessible via a driver transaction from the controller. (See the Programmatic Interface Section 6.7 of the LXI Event Logs Extended Function document)

Logging shall be enabled or disabled via a driver command. The timestamps in the LXI Event Log shall be:

- Based on the local IEEE 1588 clock if implemented, else
- Shall be either 0 or based on a time base consistent with the current IEEE-1588 time base of the system.

#### ***Observation – Clarification of Intent of Rule 3.7***

The existence of such a log is invaluable in debugging a distributed LXI system.

#### ***Observation – Size of Log File***

There is a trade-off between memory space/cost in the LXI Device and the frequency of logged events and the desired history time. Experience gives us a minimum recommended log size that is large enough to hold the most recent 256 event records. Even larger log files will make debugging easier.

### **3.7.1 Recommendation – Events to Be Logged**

In addition to the logging required by 3.7, devices should log any events that are significant to the instrument or application domain, including driver commands, triggers of any form, or significant internal state change.

Vendors are allowed and encouraged to log additional events that are appropriate and meaningful for the application domain and device functionality.

## 4 Device-to-Device Data Communication of LXI Event Messages

Device-to-device messages are LXI Event Messages that are either multicast on the LAN via UDP or transmitted through a point-to-point TCP connection. Each message is timestamped and signals the occurrence of some LXI Event in the system. LXI Devices in the system can be programmed to broadcast messages (or not) as needed.

The rules and content related to LXI Event Messages is in the *LXI Event Messaging Extended Function* document.

## 5 LXI Device Wired Trigger Bus

The LXI Device Wired Trigger Bus implements a cabling system to interconnect multiple LXI Devices. The physical interface builds upon the TIA/EIA-889 Multipoint Low Voltage Differential Signaling (M-LVDS) standard. This standard uses differential current driven signals to exchange data between semiconductor devices. Each LXI Device supporting the LXI Wired Trigger Bus has a minimum of two Trigger Bus connectors. This provides a pass-through connection of the bus by routing signals through each participating instrument. A termination device is required at the end of each LXI Wired Trigger Bus connection segment, provided by the LXI Wired Trigger Bus Terminator. The terminator attaches to the second connector at each segment end, as seen in Figure 5.1.

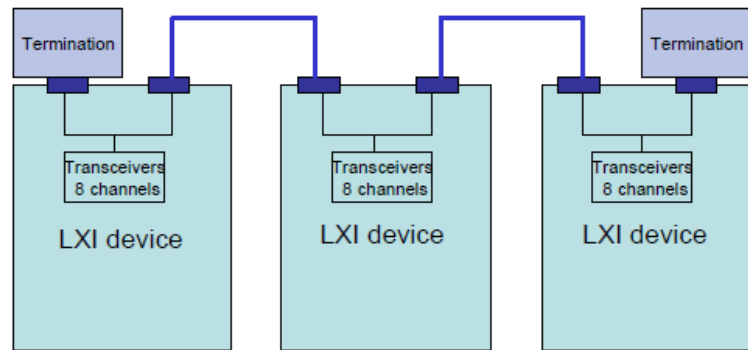

Figure 5.1 Configuration of LXI Devices using the LXI Wired Trigger Bus

The LXI Wired Trigger Bus provides eight physically independent trigger channels, matching the number of logical channels provided by the LXI Event Message mechanism in the LXI standard. The LXI Wired Trigger Bus designates LXI0 to LXI7, while the LXI Event Message designates identifiers LAN0 to LAN7.

Trigger events made through the LXI Wired Trigger Bus or the LXI Event Message trigger system are interchangeable, since the trigger model is consistent in each mode of operation.

The rules and content related to the LXI Device Wired Trigger Bus is in the *LXI Wired Trigger Bus Extended Function* document.

## 6 LXI Programmatic Interface (Drivers)

The following rules will guide the software characteristics of LXI Devices. Software synergy is important to ensure LXI Devices are easy to integrate with each other and the test program. Customers need a single standard driver to ensure interoperability.

Where noted, rules involving 6.1, 6.3, 6.4, and 6.5 refer to one or more of the following LXI Extended Functions:

- *LXI Event Messaging*
- *LXI Wired Trigger Bus*
- *LXI Clock Synchronization*
- *LXI Event Logging*

### 6.1 RULE – IVI Driver Requirement

All LXI Devices shall provide an IVI Specific Driver. The details of this requirement are called out in Section 5 of IVI-3.1. If an LXI Device is a reasonable match to an existing IVI Class specification, its driver shall be compliant to that IVI Class<sup>9</sup>.

#### 6.1.1 RULE – Trigger and Event Required API

IVI drivers for LXI Devices shall conform to the IVI-3.15 IviLxiSync specification when required by an LXI Extended Function.

---

<sup>9</sup> For more information on IVI or to download the specifications, see [www.ivifoundation.org](http://www.ivifoundation.org)

## 6.2 RULE – Syntax of the Device Address

LXI IVI Drivers shall accept VISA resource names.

The IVI driver provided with an LXI Device may use whatever underlying protocol is permitted by sections 8.1. However, the driver shall accept any valid VISA resource name as the network resource location as described in this section.

Specifically, valid VISA resource names for LXI Devices are:

```
TCPIP[board]::host address[::LAN device name][::INSTR]
TCPIP[board]::host address::port::SOCKET10
TCPIP[board]::host address[::HiSLIP device name[,HiSLIP
port]][::INSTR]
TCPIP[board]::credential information@host address::HiSLIP device
name[,HiSLIP port]][::INSTR]
```

Where:

- *board* is an integer representing a physical network interface card in the computer
- *host address* is either a hostname or IP address (4 bytes in decimal separated by “.”)
- “*INSTR*” is the resource class. It implies a protocol that supports read, write, trigger, status, and clear
- “*SOCKET*” is the resource class. It implies a protocol based on a raw tcp/ip connection that may only support read/write.
- *HiSLIP device name* indicates the subaddress of the HiSLIP server within the device. It begins with ‘hislip’. ‘hislip0’ is typically used when there is only a single subaddress.
- *HiSLIP port* is the port number to use for connections, the default value shall be the IANA assigned port 4880.
- *credential information* specifies to the driver what credentials to use to securely connect to the driver. The way that drivers acquire the credentials from this token is driver specific. The credential information may be preceded by a hash (#) or dollar sign (\$). For details of the use of this information, see VPP4.3.

Although VISA does not specify that the data being read/written to the device is an ASCII instrument control language (such as SCPI), it is implied by the INSTR and SOCKET resource classes.

If the driver supports control of the device via either the SOCKET or INSTR protocols, the driver shall use the specified protocol, unless a subsequent driver call or initialization string alters that behavior.

The driver shall choose the most appropriate protocol for controlling that device. For the INSTR resource class the LXI Device name may be used to specify a port. If the IP port, the LXI Device name, or resource class is not relevant for that protocol, the driver shall ignore the irrelevant parameters.

Note that this resource descriptor may be passed directly by the customer to the open call or it may be extracted from the IVI Configuration Store.

### **Observation – Different Protocols May Be Supported by Additional Drivers**

If vendors wish to support multiple protocols for controlling their instrument, drivers for each protocol may be provided.

---

<sup>10</sup> For additional information see VPP-4.3.docs at <http://www.ivifoundation.org/Downloads/Specifications.htm>



***Observation – SCPI Is Not Required***

The LXI spec does not require an underlying SCPI interface to the device. LXI presumes the primary control interface is IVI.  
The actual communication between the driver and the device is at the discretion of the device designer to optimize the performance and price of the device.

### 6.3 RULE – IVI Property for Referencing a Signal Source

Any IVI interface referencing an LXI Wired Trigger Bus signal or LXI Event Message as an input shall have a string property named Source, or ending in Source, if there is a prefix. All actions within a device, which can be triggered by an LXI Wired Trigger Bus line, IEEE 1588 alarm, or LXI Event Message, shall be configurable via an interface that has a source property as stated in Rule 6.2 of the LXI Device Specification.

### 6.4 RULE – Eight LXI Events for Arm/Trigger and Eight for LXI Event Messages

LXI Devices having an Arm-Trigger state machine shall provide a minimum of eight LXI Event inputs for arm and trigger purposes and eight LXI Event Message outputs for signaling other devices.

Illustrative example block diagram of LXI Sync Subsystem (**not part of Rule 6.4**).

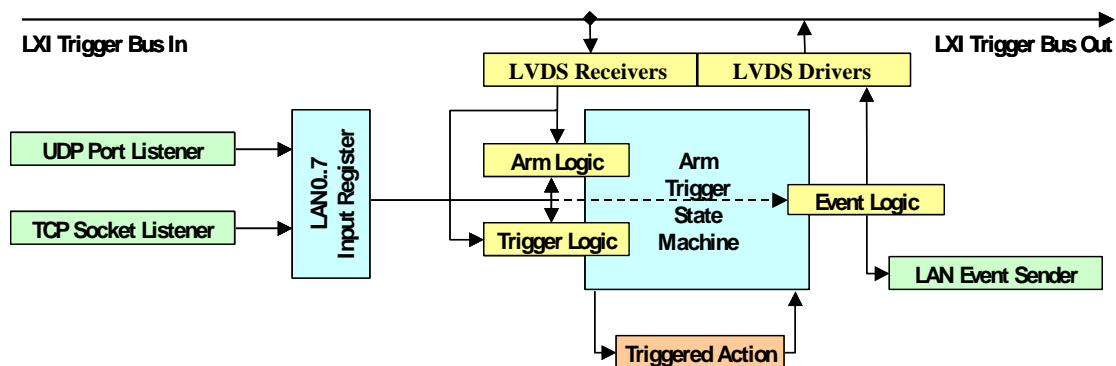

#### 6.4.1 Recommendation – Adding Additional Arm/Trigger Sources and Events

LXI Devices having an Arm-Trigger state machine should provide extensibility in their Arm, Trigger, and Event interfaces using Add() and Remove() methods.

#### 6.4.2 RULE –IVI-3.15 IviLxiSync API Routes Events to LAN

All LXI Devices capable of routing a signal to the LXI Wired Trigger Bus or to the LXI Event Sender shall be capable of doing so using the IVI-3.15 IviLxiSync API.

#### 6.4.3 RULE – LXI Events Encode the Sense of the Event in Packet

All devices transmitting LXI Events whose signal source (the signal causing the event) is:

- *one of the LXI Wired Trigger Bus lines,*
- *one of the signals from an Arm-trigger state machine, or*
- *based on a logical signal within the device*

shall encode the state of the source signal immediately following the transition that caused the event in Flag Bit 2 (Hardware Value)—which is reserved for the logical value of the event signal—and set

Flag Bit 4 (Stateless Event) to 0. Hence, a rising edge transition records a logical one and a falling transition records a logical zero.

All devices transmitting LXI Events whose signal source is not based on logical signals as described in the previous paragraph (i.e., they are stateless or have some other semantics) shall have Flag Bit 4 (Stateless Event) set to 1. See also Section 3.3.8 of the LXI Event Messaging Extended Function.

### 6.4.4 RULE – Standard Strings Used to Designate Events

The strings listed in the following tables shall be used as indicated for triggering, synchronization, and LXI Event generation purposes. Devices are not required to implement all signals. Signal names are case sensitive.

#### Observation – User Defined Strings of EventIDs

Section 4.3 of the LXI Event Message Extended Function document permits users to generate application specific EventID strings. Rule 6.4.4 only defines the use of LXI defined EventID strings. This rule does not preclude the use of user defined EventIDs for triggering, synchronization, LXI Event generation or any other purpose.

**Note:** This state machine example is not a part of Rule 6.4.4.

Example Arm-Trigger State Machine (for signal name reference purposes).

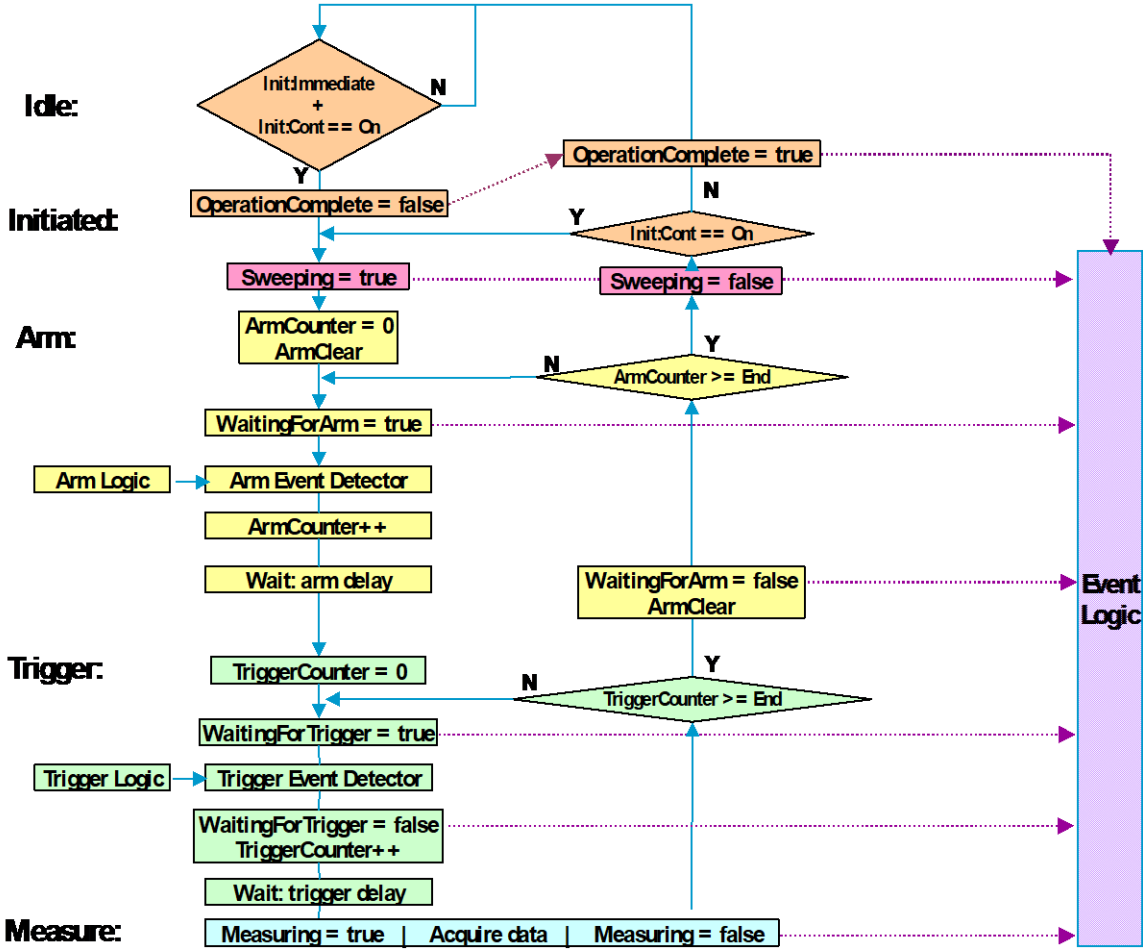

## Arm-Trigger State Machine Signal Relationships:

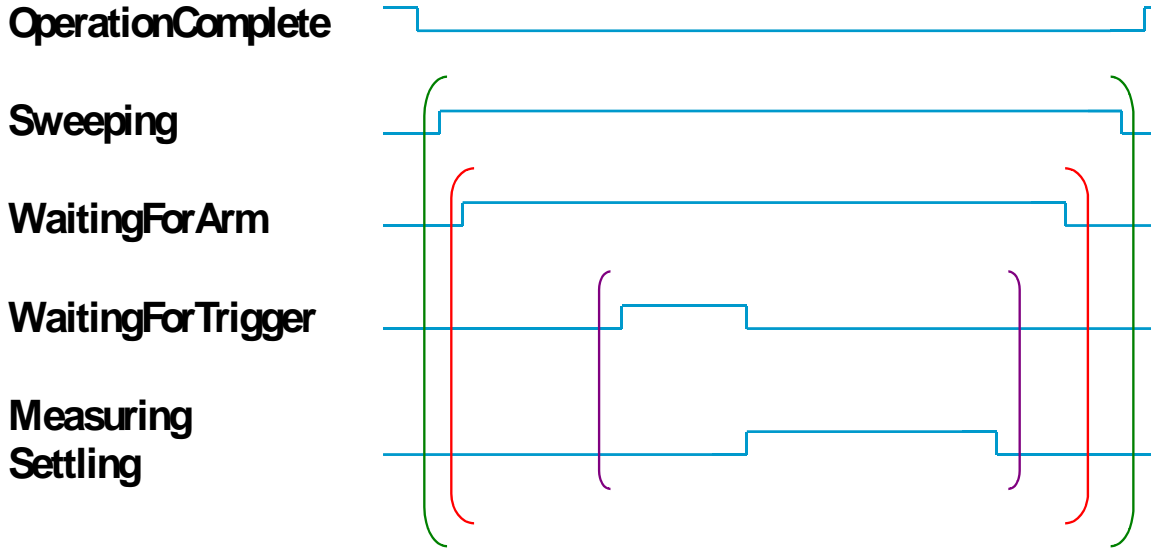

( May Occur multiple times )

**Note:** These strings are for Triggering and Synchronization. They are case sensitive.

String	Usage
LXI0	All repeated capability names referring to LXI Wired Trigger Bus line 0. All Source properties needing to refer to LXI Wired Trigger Bus line 0. As a signal Source in the IviEvents interface.
LAN0	All repeated capability names referring to LXI Event 0. All Source properties needing to refer to LXI Event 0. This is the LAN analog to LXI0. As a signal Source in the IviEvents interface. LXI Event Message shall have Stateless Event (Flags Bit 4) set to 0 (zero).
LXI1	All repeated capability names referring to LXI Wired Trigger Bus line 1. All Source properties needing to refer to LXI Wired Trigger Bus line 1. As a signal Source in the IviEvents interface.
LAN1	All repeated capability names referring to LXI Event 1. All Source properties needing to refer to LXI Event 1. This is the LAN analog to LXI1. As a signal Source in the IviEvents interface. LXI Event Message shall have Stateless Event (Flags Bit 4) set to 0 (zero).
LXI2	All repeated capability names referring to LXI Wired Trigger Bus line 2. All Source properties needing to refer to LXI Wired Trigger Bus line 2. As a signal Source in the IviEvents interface.
LAN2	All repeated capability names referring to LXI Event 2. All Source properties needing to refer to LXI Event 2. This is the LAN analog to LXI2. As a signal Source in the IviEvents interface. LXI Event Message shall have Stateless Event (Flags Bit 4) set to 0 (zero).
LXI3	All repeated capability names referring to LXI Wired Trigger Bus line 3. All Source properties needing to refer to LXI Wired Trigger Bus line 3. As a signal Source in the IviEvents interface.
LAN3	All repeated capability names referring to LXI Event 3. All Source properties needing to refer to LXI Event 3. This is the LAN analog to LXI3. As a signal Source in the IviEvents interface.

	LXI Event Message shall have Stateless Event (Flags Bit 4) set to 0 (zero).
LXI4	All repeated capability names referring to LXI Wired Trigger Bus line 4. All Source properties needing to refer to LXI Wired Trigger Bus line 4. As a signal Source in the IviEvents interface.
LAN4	All repeated capability names referring to LXI Event 4. All Source properties needing to refer to LXI Event 4. This is the LAN analog to LXI4. As a signal Source in the IviEvents interface. LXI Event Message shall have Stateless Event (Flags Bit 4) set to 0 (zero).
LXI5	All repeated capability names referring to LXI Wired Trigger Bus line 5. All Source properties needing to refer to LXI Wired Trigger Bus line 5. As a signal Source in the IviEvents interface.
LAN5	All repeated capability names referring to LXI Event 5. All Source properties needing to refer to LXI Event 5. This is the LAN analog to LXI5. As a signal Source in the IviEvents interface. LXI Event Message shall have Stateless Event (Flags Bit 4) set to 0 (zero).
LXI6	All repeated capability names referring to LXI Wired Trigger Bus line 6. All Source properties needing to refer to LXI Wired Trigger Bus line 6. As a signal Source in the IviEvents interface.
LAN6	All repeated capability names referring to LXI Event 6. All Source properties needing to refer to LXI Event 6. This is the LAN analog to LXI6. As a signal Source in the IviEvents interface. LXI Event Message shall have Stateless Event (Flags Bit 4) set to 0 (zero).
LXI7	All repeated capability names referring to LXI Wired Trigger Bus line 7. All Source properties needing to refer to LXI Wired Trigger Bus line 7. As a signal Source in the IviEvents interface.
LAN7	All repeated capability names referring to LXI Event 7. All Source properties needing to refer to LXI Event 7. This is the LAN analog to LXI7. As a signal Source in the IviEvents interface. LXI Event Message shall have Stateless Event (Flags Bit 4) set to 0 (zero).
LXIERROR	Reserved for LXI defined error events. LXI Event Message shall have Stateless Event (Flags Bit 4) set to 1.

**Note:** These strings are for LXI Event Generation. They are case sensitive

String	Usage
OperationComplete	Used as a signal Source in the IviEvents interface. In the Arm-Trigger state machine: this signal is set false when transitioning from the Idle state to the Initiated state. It is set true when transitioning from the initiated state into the Idle state. LXI Event Message shall have Stateless Event (Flags Bit 4) set to 0 (zero).
Measuring	Used as a signal Source in the IviEvents interface. In the Arm-Trigger state machine of a measuring device: this signal is set true when transitioning out the bottom of the Trigger state. It is set false when transitioning into the Trigger state from below. LXI Event Message shall have Stateless Event (Flags Bit 4) set to 0 (zero).
Settling	Used as a signal Source in the IviEvents interface. In the Arm-Trigger state machine of a source or signal conditioning device: this signal is set true when transitioning out the bottom of the Trigger state. It is set false when transitioning into the Trigger state from below. LXI Event Message shall have Stateless Event (Flags Bit 4) set to 0 (zero).
Sweeping	Used as a signal Source in the IviEvents interface. In the Arm-Trigger state machine: this signal is set true when transitioning from

	the Initiated state to the Arm state. It is set false when transitioning from the Arm state into the Initiated state. LXI Event Message shall have Stateless Event (Flags Bit 4) set to 0 (zero).
WaitingForArm	Used as a signal Source in the IviEvents interface. In the Arm-Trigger state machine: this signal is set true in the Arm state to enable the Arm logic. It is set false when transitioning from the Trigger state into the Arm state. LXI Event Message shall have Stateless Event (Flags Bit 4) set to 0 (zero).
WaitingForTrigger	Used as a signal Source in the IviEvents interface. In the Arm-Trigger state machine: this signal is set true in the Trigger state to enable the Trigger logic. It is set false after a trigger has been received. LXI Event Message shall have Stateless Event (Flags Bit 4) set to 0 (zero).
All	Used as a hostname in the Event destination. This implies the use of a UDP multicast packet to send the LXI Event.

#### 6.4.4.1 **RULE – Only Signals Corresponding to Implemented Capability Required**

Devices which only implement a portion of the Arm-trigger state machine shall only be required to implement those signals relating to the implemented portion.

#### 6.4.4.2 **RULE – Devices Shall Document Supported Signals**

Every device shall document which signals are supported.

#### 6.4.5 **RULE – LXI Event Names Beginning with LXI Reserved**

The LXI Consortium reserves all strings used for LXI Event names beginning with LXI for future standardization. Such strings shall not be used for any LXI Event or trigger name that is not sanctioned by the consortium.

#### 6.4.6 **RULE – Destination Path Syntax**

Destination path syntax for LXI Events shall be ([ ] denote optional items):

`<Destination Path> ::= [host[:port]][/name][,<Destination Path>]`

If not present, the values for the optional items are:

host	The local device (most appropriate for LXI Wired Trigger Bus events). Host 'All' sends a UDP Multicast packet to all devices using the IANA registered host address for LXI Events. Any other explicit host entry sends events via a TCP stream connection.
port	The IANA registered port (5044) for LXI Events.
name	The Item string parameter used to select this LXI Event. This is the name associated with the event object.

#### 6.4.7 **Recommendation – Create TCP Event Connections in Advance**

LXI Events sent via TCP streams should build the TCP connection when the event enable is set true and should tear down the connection when the enable is set false. This minimizes the latency to transmit the event to the receiver at time of occurrence.

## 6.5 RULE – API Time Representation

All IVI interfaces shall represent IEEE 1588 time, time-stamps, or alarms in a fashion that retains the IEEE 1588 dynamic range and resolution.

### ***Observation – Explanation of Selected Time Representation***

IEEE 1588 time needs to have sufficient resolution to represent nanosecond differences across time spans of multiple decades.

### ***Observation – Representing Time with Fundamental Data Types***

For programming environments that do not have data types that directly represent time in a way that maintains IEEE 1588 range and resolution, implementations should use two 64-bit floating point numbers, one containing the whole seconds portion, and another containing fractional seconds.

#### 6.5.1 **Deprecated RULE – Property Names for Real-Time Representation**

#### 6.5.2 **Deprecated RULE – Property Names for Real-Time Timestamp**

#### 6.5.3 **Recommendation – Use a Single Timestamp for Data Sets**

If the interface for returning measurement data provides a summary data set in which it is appropriate to include the timestamp, device designers are encouraged to use this means for associating the timestamp with the data, rather than adding two properties to the interface as it couples the data with the timestamp more securely.

## 6.6 RULE – Domain Property to Facilitate Multiple Systems on a Single LAN

All LXI Devices implementing LXI Events shall include a property named LXIDomain of type LONG for setting the LXI domain field transmitted and received in all LXI Events. The allowed range of this property is 0 – 255. The default value for this property shall be zero.

#### 6.6.1 **Recommendation – Domain Property Is Persistent**

The value of the LXIDomain property should persist through power cycles of the device.

#### 6.6.2 **Recommendation – Location of Domain Property in API**

The LXIDomain property should be placed in the same interface that contains the instrument I/O object (if present). This is commonly named System (often with a prefix).

## 6.8 Recommendation – Control Identification Light

Devices should include a programmatic interface to control the Device Identity indication (part of the LAN Status indicator). This should be implemented as a Boolean property. For details of the behavior of the Device Identity indication, see [RULE 8.10](#)



## 7 LAN Specifications

### 7.1 RULE – Ethernet Required

LXI Devices shall implement Ethernet for a physical connection, this shall be a minimum of 100 Mb/s, IEEE 802.3 Type 100 BASE-TX.

#### 7.1.1 Recommendation - Gigabit Ethernet

LXI Devices should support Gigabit (Type 1000BASE-T) Ethernet.

#### 7.1.2 RULE – Proper Operation in Slower Networks

LXI Devices shall operate properly in Ethernet networks of equal or slower speed than themselves, at least down to 100 Mb/s Ethernet. If LXI Devices can operate at 10 Mb/s, they shall be IEEE 802.3 Type 10 BASE-T.

#### ***Observation – Ethernet Networks and Backwards Compatibility***

Ethernet networks are usually backward compatible such that Ethernet devices with different maximum speeds can interoperate together. LXI Devices must have the capability of operating on a 100 Mb/s only network.

### 7.2 RULE – MAC Address Display

LXI Devices shall display the MAC address of the LXI Device via a user-accessible display or label affixed to the LXI Device. The MAC address is not changeable.

#### 7.2.1 Recommendation – MAC Address Visible While in Rack

The MAC address should be viewable while the LXI Device is in a rack.

### 7.3 RULE – Ethernet Connection Monitoring

LXI Devices shall incorporate Ethernet connection monitoring (one possible implementation of which is commonly known as Media Sense in Microsoft operating systems). Upon detecting a connection event, the current IP configuration shall be validated (including duplicate IP address detection) and, if necessary, updated.

#### **Observation**

From observation of several devices being tested, the behavior of a LAN Stack includes using last valid DHCP address – an ARP request is required to validate the availability of the IP address – until such time as it acquires a new DHCP lease or times out looking for a DHCP server (approximately 2 minutes). If no DHCP server is found, the device shall fall back to a Link Local address. It is not clear that we could hold off the LAN Status indicator in this case because the LAN Stack thinks everything is just fine for the moment.  
The test procedure specifically allows the above behavior as long as the timeout is no longer than the normal search for a DHCP Server.

#### **Observation – Advantages of Connection Monitoring**

Ethernet connection monitoring (e.g. Media Sense) allows a network host’s operating system and applications to respond to the network media being connected and disconnected. Responses to link detection (media connected) might include network configuration.

### 7.4 Recommendation – Incorporate Auto-MDIX

LXI Devices should incorporate Auto-MDIX.

### 7.5 RULE – Label Required on LXI Devices Without Auto-MDIX

If Auto-MDIX is not supported the LXI Device shall be clearly labeled with a physical, human-readable label. A “soft” label, on an instrument display, for instance is insufficient.

#### **Observation – Purpose of Auto-MDIX**

Auto-MDIX functionality, built into Ethernet PHY devices, allows network equipment to be connected without the need for special “crossover” cables, simplifying installation, troubleshooting, and maintenance. Currently, 1GB or higher LAN devices incorporate Auto-MDIX. This industry trend is expected to continue. The requirement for a physical label is to remove confusion when connecting LXI Devices to networks or diagnosing connectivity issues.

## 7.6 RULE – Enable Auto-Negotiation by Default

LXI Devices should support auto-negotiation by default to select the highest operating mode. In most cases, Auto-Negotiation eliminates the need for the user to explicitly set the operating modes at both ends of the cable. Most Ethernet products enable Auto-Negotiation by default.

### 7.6.1 Recommendation – Provide Override for Auto-Negotiation

LXI Devices should also provide a way for the user to override Auto-Negotiation for those (rare) situations when the results of Auto-Negotiation may not be what the user wants. The auto-negotiate process in this case may select an operating mode that is too high for the installed cabling. For these reasons, it is recommended that LXI Devices allow the user to override Auto-Negotiation.

#### **Observation – Purpose of Auto-Negotiation**

Auto-Negotiation is the Ethernet capability to automatically determine the proper Ethernet link speed and duplex mode. The Auto-Negotiate process works by having each Ethernet device exchanging its speed/duplex capabilities with the other end of the cable, and then the highest operating mode available on both ends is selected.

The implementation of Auto-Negotiation has both hardware and software components. The software parts of Auto-Negotiation are documented below. With respect to the entire network software set, Auto-Negotiation is part of the Ethernet driver. For reference, these are the modes supported by Ethernet (note that Gigabit Ethernet is always full duplex):

Ethernet Speed	Ethernet Duplex Mode
100 Mbits/sec	Half
100 Mbits/sec	Full
1000 Mbits/sec	Full

## 7.7 RULE – Multiple LAN Interfaces

If multiple LAN interfaces (NIC's) are present in an LXI Device, at least one of them shall be fully conformant with the LXI Device Specification (Rule 1.4.4.2.1). The other NIC's don't have to provide any LXI capabilities.

If a vendor decides that all the NIC's are LXI capable, then they shall be fully conformant with the LXI Device Specification (web server, mDNS, XML identification schema etc.). All NIC's claiming to be LXI conformant will be tested when submitted for LXI Compliance Testing.

#### **Observation - Use separate NIC for LXI Extended Functions**

It may be a good idea to have one NIC fully conformant with the LXI Device Specification and use other NIC(s) for the extended functions: Event Messaging, Clock Synchronization, IPv6, etc.

All LAN interfaces that provide any LXI Extended Functions only, as in the above observation, shall advertise the functionality of that interface. To “Advertise and Display” Multiple LAN Interfaces, either of the following two alternatives listed are acceptable methods:

1. The web pages, xml identification schema, mDNS, etc., contain or advertise the information for ALL LXI conformant NIC's on all NIC's.
2. The web pages, xml identification schema, mDNS, etc., contain or advertise the information pertinent to the NIC through which the query was received

## 8 IPv4 LAN Configuration

The following sections describe IPv4 requirements. See the LXI IPv6 Extended Function for rules related to IPv6 implementations and additional requirements regarding IPv4.

### 8.1 RULE – TCP/IP, UDP, IPv4 Network Protocols

LXI Devices shall support TCP/IP networking, as outlined in a number of RFCs, including RFC 791 (IP), RFC 793 (TCP), and RFC 768 (UDP). IPv4 shall be supported at a minimum.

LXI Devices can be controlled and communicated with using any higher-level protocol (such as RPC), as long as it is built on top of the TCP or UDP transport layers.

#### 8.1.1 Recommendation – LXI Devices should also support IPv6 to ensure long-term network compatibility

##### *Observation – supporting IPv6*

Any implementation of IPv6 should follow the [LXI IPv6 Extended Function](#)

### 8.2 RULE – ICMP Ping Responder

LXI Devices shall support IPv4 ICMP (Internet Control Message Protocol, used for a Ping Responder).

The TCP/IP stack shall be able to respond to the ICMP echo message used by the ping command. The ‘ping <hostname>’ or ‘ping <IP address>’ command is the standard way to determine whether a user’s connection to an Ethernet device is working.

### 8.3 RULE – ICMP Ping Responder Enabled by Default

ICMP Ping service (“Ping Responder”) shall be enabled by default.

### 8.4 Rule – Provide Way to Disable ICMP Ping Responder

LXI Devices shall provide a way to disable the IPv4 ICMP ping responder.

##### *Observation – Disabling ICMP Ping Responder*

Disabling the ICMP Ping Responder minimizes the risk that unauthorized people would find, connect to, and alter the configuration of the LXI Device.

### 8.5 Recommendation – Support ICMP Ping Client

LXI Devices should support ICMP Ping Client capability so that the user can ping other Ethernet devices.

##### *Observation – Ping Client Usage*

An ICMP Ping Client available in a device may be useful in debugging communication problems with a TCP/IP configuration on a device.

## 8.6 RULE – IP Address Configuration Techniques

LXI Devices shall support three LAN configuration techniques: DHCP, Dynamically Configured Link Local Addressing (Auto-IP), and manual. LAN configuration refers to the mechanism that the device uses to obtain IP Address, Subnet Mask, Default Gateway IP Address, and DNS Server IP Address(es).

Collectively, DHCP and Dynamically Configured Link Local Addressing are considered automatic configuration methods. These automatic methods may provide additional or supplemental user entries for DNS servers as appropriate. The DHCP and Manual configuration methods provide configuration for: 1) device IP address, 2) Subnet Mask, 3) Default Gateway IP Address, 4) DNS server IP addresses.

### ***Observation – Dynamic Link-Local Addressing***

Dynamically Configured Link-Local Addressing allows automatic IP address setup on small ad-hoc networks without DHCP servers. Networks without DHCP servers are common on small private networks without network administrators. An LXI Device hooked directly up to a laptop with an Ethernet crossover cable is very likely to use Dynamic Configured Link-Local Addressing.

### ***Observation – Manually Configured Networks***

Manually configured networks might be used on small test systems in which a user desires complete control of device IP configuration. Also, some users do not permit Dynamic Configured Link-Local Addressing on their networks.

### ***Observation – DHCP Used for Automatic IP Assignment***

Dynamic Host Configuration Protocol (DHCP) is widely used to centrally manage networks and automate IP address assignments. DHCP involves a DHCP server and several DHCP clients.

A DHCP server may be set up for large public networks or for local private subnet networks. Many corporate networks will have a DHCP server maintained by a network administrator that is a network-wide resource. A private subnet may have a DHCP server that is either software or hardware. A DSL/Cable router usually has a built-in DHCP server, for example. A DHCP client is supported in most operating systems, including Windows, VxWorks, and Linux.

DHCP current specifications RFC 2131 and RFC 2132 are found at the IETF Website:

"RFC 2131 Dynamic Host Configuration Protocol," R. Droms, March 1997 (Obsoletes RFC1541) (Status: DRAFT STANDARD)

"RFC 2132 DHCP Options and BOOTP Vendor Extensions," S. Alexander, R. Droms, March 1997 (Obsoletes RFC1533) (Status: DRAFT STANDARD)

"RFC 3927 Dynamic Configuration of IPv4 Link-Local Addresses," S. Cheshire, B. Aboba, E. Guttman, May 2005 (Status: Proposed Standard)

### 8.6.1 **RULE – Options for LAN configuration**

LXI Devices shall support one of the following options for LAN configuration:

A single configuration setting of Automatic (implying DHCP and Dynamically Configured Link Local Addressing) or Manual.

Individual configuration settings for: DHCP, Dynamically Configured Link Local Addressing, and Manual. If more than one is enabled, the LXI Device's LAN configuration shall proceed in the following order: 1) DHCP, 2) Dynamically Configured Link Local Addressing, 3) manual.

### 8.6.2 **Recommendation – 30-Second DHCP Timeout**

LXI Devices should implement a 30-second DHCP time-out to control how long the DHCP client will wait for a response from a DHCP server before giving up.

#### ***Observation – Length of Timeout Important***

A time-out that is too short will result in failing to contact a server, if the DHCP server is busy or the LAN is congested. On the other hand, a time-out that is too long will cause the device to appear to hang (or the network configuration to hang) while booting, if it is on a LAN with no DHCP server.

### 8.6.3 **RULE – Explicitly Request All Desired DHCP Parameters**

LXI Devices shall explicitly request all desired DHCP parameters from the DHCP server. A DHCP client uses the "parameter request list" option to request specific parameter values from a server. The LXI Device DHCP implementation should ensure that the following parameters are present in the "parameter request list":

- default gateway (not to be confused with the reset value of gateway)
- Subnet mask
- DNS Server

### 8.6.4 **Recommendation – Accept the First DHCP Offer Received**

LXI Devices should accept the first DHCP OFFER message received.

The DHCP protocol specifies that a DHCP client emit a DHCP discovery message to find a DHCP server, and then wait for DHCP offer messages from DHCP servers. The protocol allows, but does not require, the client to collect multiple offers prior to requesting an address from one of the responding servers. Some DHCP implementations accept multiple offers, but none allows the user to select which DHCP server is used. Accepting the first DHCP OFFER is the most common implementation and produces the fastest IP configuration via DHCP.

### 8.6.5 **RULE – Do Not Require Additional DHCP Options for Normal Operations**

LXI Devices shall not require any additional DHCP options for normal operations beyond what is needed for IP and DNS configuration. Other options may be requested, but the operation of the LXI Device shall not depend on receiving these parameters.

### ***Observation – DHCP Option Uses***

When generating a discover or request packet, the DHCP client (LXI Device) is permitted to send a list of DHCP options for which it requires answers before it can properly boot. The options may also be used to provide additional information to the server. This information can be used to generate a specialized reply just for that client. For example, some clients (LXI Devices) may require that a boot file name be provided, and each LXI Device may require a unique boot file for update purposes. This also implies LXI Devices have local storage.

#### **8.6.5.1 Permission – Additional DHCP Options Allowed for LXI Device Updates**

Network boot support, which requires an additional DHCP option, may be used to update LXI Devices.

#### **8.6.6 RULE – Stop Using IP Address If DHCP Lease Not Renewed**

If an LXI Device is unable to renew its DHCP lease it shall stop using the DHCP supplied IP configuration that failed to be renewed and LAN Status Indicator must indicate a fault (See Rule 8.10)

#### **8.6.7 RULE – Honor New DHCP Options at Lease Renewal**

LXI Devices shall honor new DHCP options provided when renewing a lease.

### ***Observation – DHCP Lease Renewal***

When a DHCP client renews a lease or validates a current lease via a request transaction, it is possible for the DHCP server to send a reply with different option values than it sent when first sending the lease. For example, the DHCP server may specify a new DNS server to use. The implication is that the server wants the client to use the new values; however, this is not explicitly stated in the DHCP protocol. The DHCP client should honor new DHCP options provided, when renewing a lease.

#### **8.6.8 Recommendation – Provide Manual DNS IP Address Entry**

LXI Devices should allow the user to enter DNS server(s) IP addresses. The automatic IP configuration with manual DNS configuration enables the user to select a specific DNS configuration in addition to the DHCP configuration information. This is useful in network environments with a DNS server per department and a DHCP server per site.



### ***Observation – Manual Network Configuration***

Some TCP/IP networks require each device to be manually configured with an IP address, subnet mask, default gateway, and optionally DNS server(s) IP addresses. On manually configured networks, the network administrator will provide the network configuration values to the device user.

### **8.6.9 Permission – User Configured Hosts File Allowed**

LXI Devices may support a user configured hosts file.

Some LXI Devices that will have users running many network client applications (web browsing, etc.) directly on the LXI Device may want to support the ability to set up a hosts file. A hosts file is a manual way for the user to set up specific mappings between hostnames and IP addresses.

### **8.6.10 RULE – Dynamic Link-Local Address**

LXI Devices shall conform to RFC 3927 Section 2.6.2

### ***Observation – Default Route with Dynamic Link-Local Addressing***

Implementers should take particular note of section 2.6.2 of RFC 3927 "Dynamic Configuration of IPv4 Link-Local Addresses", which addresses forwarding rules for devices operating with Dynamic Link-Local Addresses. Proper implementation of this (e.g., configuring a default route of the Dynamic Link-Local Address or network interface) supports communication between devices with routable addresses and devices with link-local addresses on the same network segment.

## 8.7 RULE – Duplicate IP Address Detection

LXI Devices shall perform duplicate IP address detection to ensure an LXI Device does not start using an IP address that is already in use on that network.

LXI Devices shall disconnect from the network when a duplicate IP address is detected.

### ***Observation – Duplicate IP Address Detected***

The intention and spirit of Rule 8.7 is to prevent misconfigured LXI devices from interfering with other devices on a network. An LXI device will **always** check to see if an IP address it has been assigned is in use before using it. This is true for DHCP assigned addresses, Link-Local addresses or static IP addresses. This is also true for whichever method is used to change the IP configuration: front panel, Web page, Power on or pressing the LAN Configuration Initialization mechanism.

What the device does when it has detected a duplicate address can be one of the following options but whichever method you use the device must not use the duplicate IP address:

1. When the duplicate address has been detected, the device should show an assigned IP address of 0.0.0.0 and show a LAN fault on the LXI LAN Status Indicator.
2. When the duplicate address has been detected, the device can fall back to the currently valid IP address and not show a fault on the LXI LAN Status Indicator.
3. When the duplicate address has been detected the device can fall back to an Auto-IP address (169.254.x.x) and show a fault on the LXI LAN Status Indicator.
4. For issues related to IPv6 Duplicate IP detection refer to LXI IPv6 Extended Function

## 8.8 Recommendation – Check Network Configuration Values for Validity

The values entered by the device user should be checked to ensure they are in the valid range.

## 8.9 Recommendation – Single Hostname for All Naming Services

LXI Devices should have a single device default hostname used for all dynamic naming services. The single device hostname shall be a legal DNS name.

Default Hostname syntax recommendations:

- *Maximum length of 15 characters.*
- *First character must be a letter (RFC 1035).*
- *Last character must be either a letter or a digit (RFC 1035).*
- *Intervening characters must be either a letter or a digit or a hyphen (RFC 1035).*

### Observation – Hostname Naming Conventions

The above Hostname naming convention is only a recommendation. Hostnames should be any valid hostname. RFC 921 and RFC 1035 dictate these recommendations. Subsequently, RFC 1123 allowed the first character to be a numeric value. There are also RFCs 5890-5893 dealing with Unicode characters. The RFC 589x series is the current mechanism to encode Unicode strings into something that conforms to RFC 1123.

Hostnames are now allowed to be up to 63 characters. This LXI recommendation for hostnames is more restrictive than required in practice.

## 8.10 RULE – Provide an Error Indicator for LAN Configuration Faults

LXI Devices shall make use of the LXI LAN Status Indicator to inform the user of a LAN fault or error caused by:

- *failure to acquire a valid IP address*
- *detection of a duplicate IP address*
- *failure to renew an already acquired DHCP lease (failure to obtain an initial DHCP lease is not a failure)*
- *LAN cable disconnected (as reported by Ethernet connection monitoring)*

See [Section 2.5.2](#) LAN Status Indicator for annunciation details.

The LXI LAN Status indicator indicates both the LAN error conditions above and provides an *identify* indication as described in [Section 2.5.2](#). This identifying indication is initiated by the user via the Web interface, Section 9.3, or by the programmatic interface, Section 6.8. The LXI LAN Status indicator shall provide *LAN Fault*, *Normal Operation*, and *Device Identify* indications as shown in the state diagram below. Note that the state labeled “State Undefined” is transitory and the behavior of the indicator is not specified.

Regarding DHCP lease renewal failure and Auto-IP, there are two cases to consider. In both cases, the instrument is configured to automatically obtain an IP Address (with both DHCP and Auto-IP on). In the first case, when the device is connected to the network, it fails to obtain an IP Address through DHCP, and therefore claims an Auto-IP address. When this happens, the LAN Status Indicator should indicate no fault.

In the second case, when the device is connected to the network, it does successfully obtain a DHCP lease. However, at a later time the device fails to renew that lease through DHCP. Per Rule 8.6.6 the device must stop using the IP Address it had obtained through DHCP at this point and the

LAN Status Indicator must indicate a fault. Now, since Auto-IP is configured the device will then obtain an Auto-IP address. Despite the fact that the device now has an Auto-IP address, the LAN Status Indicator must remain in the fault state. This is to indicate to the user that a DHCP lease renewal has failed and that the device does not have the same IP Address that it did before.

At this point, the LAN Status Indicator must remain in the fault state until one of the following happens. 1) The device successfully acquires a new DHCP lease. (This can happen if it is configured to periodically attempt to obtain a new DHCP lease.). 2) The device is restarted. 3) The LAN Configuration is reinitialized for the device by the user. (This could be done through the LCI, unplugging and re-plugging the LAN cable, or another mechanism if the device is so equipped.) In scenarios 2 and 3, the behavior when the device again attempts to obtain an address is the same as in the first case, if DHCP fails but an Auto-IP address is obtained, the LAN Status is no fault.

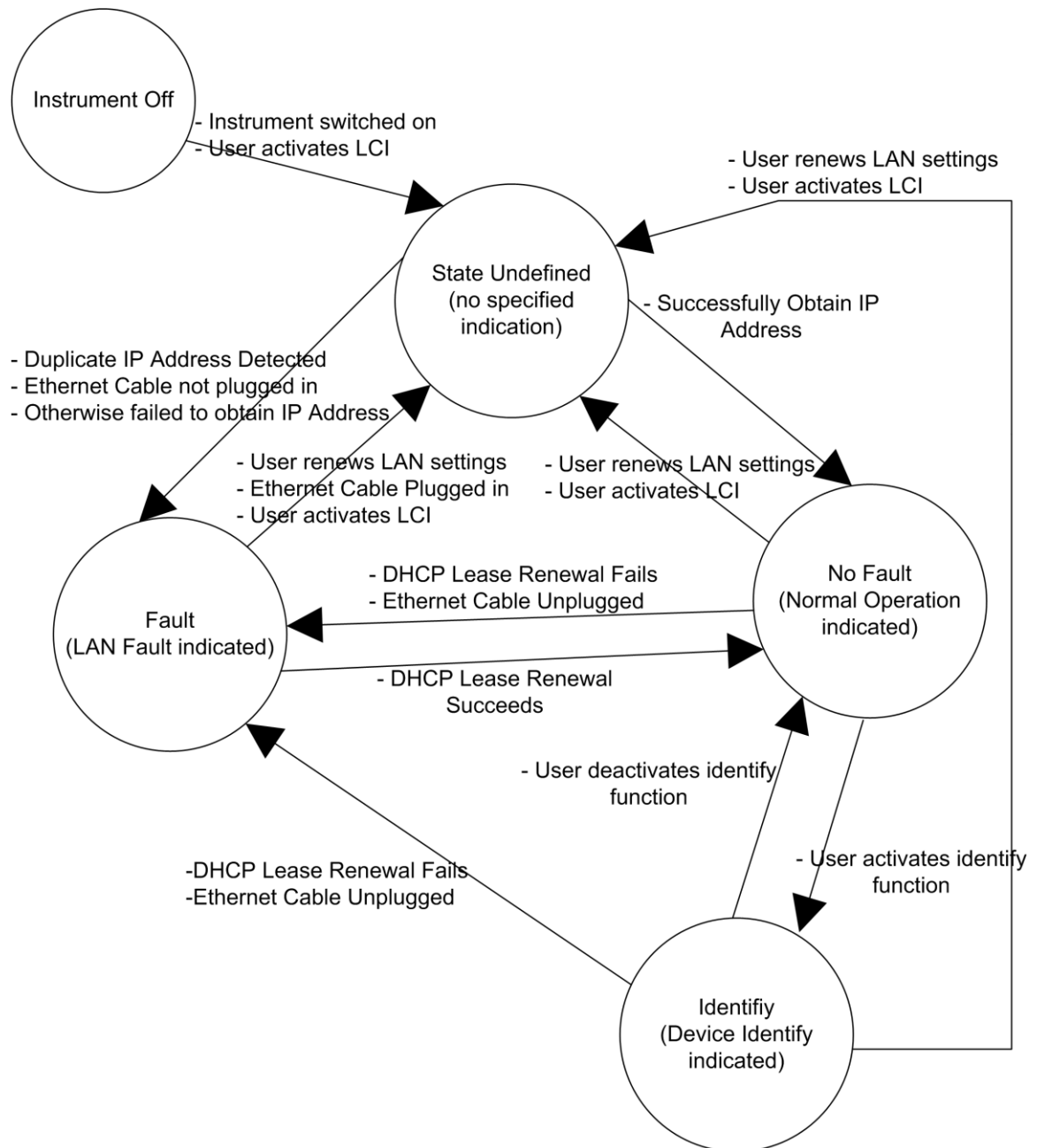

### **8.10.1 Permission – To show no fault if the LAN is inactive**

The state machine in Rule 8.10 shows that if no cable is plugged in then the LXI device shall show a fault. A LAN status indicator showing a fault when the LAN is inactive can be disconcerting to users when using the front panel display or using another Command-and-Control interface like USB.

LXI device manufacturers may show no fault on the Status Indicator when the LAN cable is not plugged.

## **8.11 Recommendation – Support Dynamic DNS Hostname Registration**

LXI Devices should support hostname registration through DHCP servers with cooperating Dynamic DNS servers.

### 8.11.1 Recommendation – Provide User Control of Dynamic DNS Registration

LXI Devices should allow the user to turn the Dynamic DNS capability on or off. On networks without Dynamic DNS support, the network ignores the hostname request sent out by the device. Some users may want to disable Dynamic DNS at the device to make use of a default hostname assigned by the network.

DHCP Options are additional IP address settings that a DHCP server passes to DHCP clients.

- DHCP Client Option 12 feature specifies the hostname of the client
- DHCP option 81 is the **Client Fully Qualified Domain Name** – this option allows automatic update of the DNS records associated to the client. This option can specify whether the client or the server will update the records and the FQDN associated to the client.

Both option 12 and option 81 should be present to enable Dynamic DNS. The reason why both options are needed is because in testing it has been found that if only option 12 is present then Windows routers which are looking at option 81 only would not disable Dynamic DNS when removing option 12 only.

Some Linux routers only listen to the option 12, therefore not having option 12 broadcasted when option 81 is set might lead to not having Dynamic DNS enabled when expected. This is due to some Linux routers not keeping entirely to the RFC.

LXI devices that support user control of Dynamic DNS should support both option 12 and option 81 when it is re-enabled. Option 12 and option 81 should be present and removed when enabling/disabling Dynamic DNS respectively. Even though having both options provide redundant information.

#### ***Observation – Kerberos Conformance Testing***

The TSEP Kerberos Test Suite checks to make sure both option 12 and option 81 are present for enabling Dynamic DNS. If both options 12 and 81 are missing Dynamic DNS is disabled.

#### ***Observation – DNS Client Usage***

The previous section discussed how to make a device reachable as a server via a hostname. This section discusses the ability of the device to become a client in the network running things like a Web browser. This capability may not be used on all devices because they have little need to become a client on the network. In order to be a client on the network the device needs to be able to do hostname look-ups just like any other computer in the network.

#### **8.11.1.1 RULE – If Dynamic DNS Can Be Disabled, Its Default State Is Enabled**

LXI Devices that allow Dynamic DNS to be turned off shall have the Dynamic DNS capability enabled by either default or after an LCI.

## 8.12 Recommendation - Provide DNS Client

LXI Devices should support a DNS client for resolving hostnames.

### **Observation – DNS Client Advantages**

DNS client capability allows an LXI Device to translate a hostname into an IP address. This capability may be used for the following applications:  
Running client applications (like a web browser) on the LXI Device to connect to other resources and/or servers on the network. This would be used, for example, to do firmware updates from a supplier’s website.

Doing reverse look-ups of IP addresses that have a connection to the LXI Device to get the hostname of the user connected, which is more recognizable than an IP address.

Enabling a connection by hostname to nodes on the organization’s LAN, such as servers or printers.

Validating the DNS hostname that the LXI Device has by doing a reverse IP-to-hostname look-up on the LXI Device’s IP address and then doing a forward hostname-to-IP address look-up to verify that it returns the LXI Device’s IP address.

## 8.13 RULE – LAN Configuration Initialize (LCI)

LXI Devices shall provide a LCI reset mechanism, as defined in Section 2.4.5, that when activated places many of the LXI Device's network settings to a specified state. These settings shall take effect when the LCI mechanism is activated, without requiring any further operator actions (e.g., if the LXI Device requires a reboot for the changes to take effect, the LXI Device shall reboot automatically).

The LCI reset mechanism may affect settings not called out by LXI that enable the customer to re-establish network communication with the device. The LXI Device LCI state shall be fully documented and available in the manufacturer’s supplied documentation.

**Table of items affected by LAN Configuration Initialize Mechanism**

Item	Value	Section
IPv4 Interface	Enabled	Pertains to devices that implement the LXI IPv6 Extended Function.
IPv4 Address Configuration: DHCP AutoIP	Enabled Enabled	8.6
ICMPv4 Ping Responder	Enabled	8.3
Web Password for configuration	Default LXI Security Extended Function obviates this setting	9.8
IPv4 Dynamic DNS (if implemented)	Enabled	8.11.1.1
mDNS and DNS-SD	Enabled	10.3, 10.4, 10.5.1, 10.7.1

If an LXI Device has a manual user interface (physical front panel) that allows the configuration of these items plus the network configuration, then that shall be sufficient to manually adjust the configurations changed by LCI

### **8.13.1 Recommendation – LAN Configuration Initialize (LCI) Additional Settings**

In addition to the settings listed in 8.13, The LCI mechanism should enable auto-negotiation.



## 9 Web Interface

### 9.1 RULE – Web Pages Using W3C Compliant Browsers

LXI Devices shall serve a HTML web page that works correctly with all W3C compliant browsers. LXI Device web servers shall conform to HTTP (HTTP/1.1 - RFC 2616) and serve content via TLS (Version 1.2 or greater – RFC 8446), this is colloquially known as HTTPS.

The HTML pages served shall conform to HTML (version 4.01 or greater) or XHTML (version 1.0 or greater).

#### **Observation – HTTP Versions**

HTTP/1.1 has been the default standard for web servers since 1999. HTTP/2.0 and HTTP/3.0 are newer and have many additional benefits, especially in performance. They also support transferring binary data more efficiently and could be a benefit for LXI Devices. HTTP/2.0 and HTTP/3.0 are backward compatible with HTTP/1.1

#### **Observation – HTTP/3.0**

HTTP/3.0 is relatively new but is gaining traction with the major browsers. It replaces the transport layer protocol TCP with a new transport protocol layer called QUIC. QUIC was developed by Google to improve the performance of HTTP connections.

#### 9.1.1 **Deprecated RULE – Protocol and Port Number**

#### 9.1.2 **Deprecated Recommendation – Web Server Root Document**

Deprecated in Version 1.6

The device web server root document (home page) should be the LXI Welcome Page (defined below) or a web page with a hyper-link to the LXI Welcome page. If the default landing page is not the LXI Welcome Page, then it should be clear and obvious how to navigate to the LXI Welcome Page from the initial landing page.

#### 9.1.3 **Recommendation – Implement HTTP/2.0**

LXI devices should implement HTTP/2.0. HTTP/2.0 is backward compatible with HTTP/1.1 and future proofs the vendors device. It is a rule (9.1) that LXI Devices need to implement HTTP/1.1 but this has been around since 1999. Browser vendors may stop support for HTTP/1.1 in the future.

#### 9.1.4 **RULE – HTTP Transport and Port Number**

The default port number for the web server shall be 443. The default web server shall use HTTP over a TLS connection, colloquially referred to as HTTPS (and henceforth referred to as HTTPS in this document).

Navigation buttons, hyperlinks or port redirection are allowed to access other ports as desired by the web page authors.

#### **Observation – HTTP Connections**

Previous versions of the LXI Standard required a HTTP Connection on port 80 (Rule 9.1.1). These Web Pages are typically unsecure. All modern browsers show warnings or prevent connections to unsecure HTTP Web Servers. Thus, LXI versions 1.6 and beyond now require a HTTPS connection instead of a HTTP connection.

The LXI Device Specification does not prevent HTTP connections to the device web server or any REST APIs that maybe supported by the device It is up to the vendor to decide if they need this capability for backward compatibility.

### **Observation – LXI API Extended Function**

The API Extended Function can disable HTTPS and change the port number.

#### **9.1.5 Permission – To still allow HTTP Connections**

HTTP connections are still allowed but not recommended. See observation in Rule 9.1.4.

For backward compatibility reasons LXI vendors should consider:

1. If the device supports only HTTPS connections, then redirect any HTTP requests to HTTPS
2. Devices that support HTTP connections should have a mechanism to disable HTTP if the customer so desires. See observation in Rule 9.1.4

#### **9.1.6 Recommendation – HTTPS X.509 Certificate Requirement**

HTTPS connections require a X.509 certificate installed on the device. To facilitate this requirement, it is recommended that the LXI Security and API Extended functions be supported by the device.

#### **9.1.7 Rule – Alias for Welcome Page**

All LXI Devices shall provide an alias or redirect for the LXI Welcome Web Page document that can be queried via a GET at: <https://<device>/lxi>.

For some LXI devices the Web Server root document is not the LXI Welcome page, so this is a convenient shortcut to get to the LXI Welcome page.

## **9.2 RULE – Welcome Web Page Display Items**

The primary LXI welcome page shall display the following information in a read-only format.

- LXI Device Model
- Manufacturer
- Serial Number
- Description<sup>11</sup>
- LXI Extended Functions
- LXI version
- Hostname<sup>12</sup>
- MAC Address <XX-XX-XX-XX-XX-XX>
- TCP/IP Address <DDD.DDD.DDD.DDD>

---

<sup>11</sup> Refer to section 9.5.1, 10.4.1, and 10.7

<sup>12</sup> Refer to sections 8.9, 9.2.3, 10.3.1, and 10.7

- Firmware and/or Software Revision
- LXI Device Address String [VISA]

If the device supports any Extended Functions check the Extended Function specification documents for any further items that need to be displayed here

### 9.2.1 RULE – LXI Device Address String on Welcome Page

The primary LXI welcome page shall contain an IVI I/O Resource Descriptor (a string such as a VISA Resource Descriptor), which is a string that specifies the address of the hardware asset that can be recognized by the I/O used by a software module that accesses the hardware. An example of such a Resource Descriptor is a VISA Resource.

For VISA Resources of the form

```
TCPIP[board]::host address[::LAN device name]
```

or

```
TCPIP[board]::host address::port::SOCKET
```

The value of “[board]” must be empty since the instrument cannot know which interface board a client may be using.

#### 9.2.1.1 Recommendation – LXI Device Address String Label

This string should be labeled “Instrument Address String.”

### 9.2.2 Recommendation – Web Page Title

An LXI Device web page title should follow the following format to align the bookmarks nicely:

```
LXI - Manufacturer-Model-<Optional Serial Number>-<Optional  
Description>
```

### 9.2.3 RULE – Actual Hostname Display

LXI Devices shall display the validated hostname(s) (DNS and/or mDNS) on the LXI Welcome Web page. The hostname(s) displayed on the LAN Configuration page need not be validated since they represent desired configuration values.

#### ***Observation – How a Hostname May Be Assigned on the Network***

The actual hostname that a device gets on a network is not necessarily the dynamic hostname that the device requested. Generally, the hostname is going to be different if the network does not support Dynamic DNS naming. The possibility of a device hostname that is different than expected makes it important for the device to determine what hostname it has really been assigned and display this in the appropriate places in the LXI Device user interface. There are also cases in which the device will not have a hostname at all and in those cases, the IP address will have to be used in place of the hostname.

The following network configurations can create a situation when the desired device hostname may be different from the real hostname:

- Device has Dynamic DNS Naming disabled
- A network without any DNS server
- A network with a non-dynamic (static) DNS server

A device that requests a hostname already in use on the network

The cases that may be confusing for the user are the ones where the dynamic hostnames in the devices are different from the real hostnames on the network. Most of these cases will involve networks with static DNS servers. On those networks, the user will have to set up the hostname they wanted with their network administrator. Attempting to register a dynamic DNS hostname with a static DNS server will just fail, and the dynamic device hostname will be ignored.

### 9.2.3.1 Recommendation – How to Determine Actual Hostname with Unicast DNS

LXI Devices should use the following algorithm to determine LXI Device hostname when using unicast DNS; it covers all the conditions described above and allows the LXI Device to determine its hostname. The algorithm is:

1. If there is a unicast DNS server address configured in the LXI Device (either via DHCP or manually configured), do the following:
  - a) Determine the LXI Device's IP address (DHCP/Manual/Dynamic Link-Local Addressing).
  - b) Do a reverse unicast DNS look-up (IP address to hostname lookup) to determine the LXI Device's hostname on the network.
  - c) If the lookup fails, then go to step 2.
  - d) Do a forward unicast DNS look-up (hostname name to IP address lookup) to validate that the hostname can be resolved, and the same IP address is returned.
  - e) If the lookup fails, then go to step 2.
  - f) If the IP address from step 1a and 1c are different, then there is something wrong with the unicast DNS hostname configuration. Proceed to step 2.
  - g) The hostname determined in step 1c is the correct hostname, and this hostname can be presented through the appropriate places in the LXI Device's user interface.
2. There is no hostname assigned to this LXI Device.
  - a) Use the IP address in place of an actual hostname, and the IP address can be presented through the LXI Device user interface.

#### ***Observation – mDNS Hostnames Require No Validation***

Given the nature of mDNS and its conflict resolution mechanism, when a device has successfully registered an mDNS hostname, the hostname requires no further validation since it is implicitly validated as part of the registration process.

### 9.2.3.2 Rule – Hostname Display

If an LXI Device does not support recommendation 9.2.3.1 or if mDNS is disabled, then it shall show the assigned IP address or a blank field for the hostname.

#### ***Observation – Hostname Display***

When displaying its hostname an LXI Device may show a unicast DNS hostname, an mDNS hostname, an IP address, or some combination of these.

### 9.2.3.3 Rule – mDNS Hostname Format

When displaying an mDNS hostname on the LXI Welcome Web page, the fully qualified mDNS hostname shall be displayed with its domain of “.local.”

#### **Observation – Using Fully Qualified Domain Names with mDNS**

To reduce potential problems with name resolution, users should specify the Fully Qualified Domain Name (FQDN) when working with mDNS hostnames. So, for example, a device with an mDNS hostname of "dev-123" should be addressed as "dev-123.local."

### 9.2.3.4 Permission – If both DNS and mDNS are enabled

If both DNS and mDNS have qualified hostnames then the multiple hostnames may be displayed in the one defined hostname field of the LXI Welcome Web page, separated by commas, or additional fields may be added on the LXI Welcome page for the additional hostnames

### 9.2.3.5 Rule – Description Field contains Resolved Service Name

The unique and resolved service name shall be shown in the description field of the Welcome page defined in section 9.1.

## 9.3 RULE – Device Identification Functionality on the Web Page

There shall be a device identification indicator functionality on the web page to control the LAN Status Indicator (see Sections [2.5.2](#) and [RULE 8.10](#)).

### 9.3.1 Permission – No password protection for device identification indicator

The device’s identification indicator functionality is not considered as an instrument setting. Therefore, the web page that exposes this functionality may not be password protected.

## 9.4 RULE – LAN and Sync Configuration Links on the Welcome Page

The Welcome page shall contain a hyperlink/button to provide further information or to allow the user to configure LXI Device settings. This link will take you to the information described in Section 9.5

If the device supports Rule 9.6 then there needs to be a hyperlink/button to access the LXI Sync Web page from the LXI Welcome page.

LXI doesn’t want to dictate how the Web page(s) are laid out but it needs to be obvious how to access the: LXI Welcome page, the LAN Configuration and optionally the LXI Sync page from the landing page of the instrument.

### 9.4.1 Recommendation – Status Page Link on the Welcome Page

There should be an additional hyperlink/button – Status/Miscellaneous page on the LXI welcome page.

## 9.5 RULE – LAN Configuration Web Page Contents

The *LXI IPv6 Extended Function* specifies requirements for the IPv6 device LAN Configuration Web Page.

The LAN configuration page shall contain the following parameters to configure the LAN settings:

- *Hostname*
- *Description*
- *TCP/IP Configuration Mode*
- *Static IP address*
- *Subnet mask*
- *Default Gateway*
- *DNS Server(s)*

The TCP/IP configuration field controls how the IP address for the instrument is assigned. For the manual configuration mode, the static IP address, subnet mask, and default gateway are used to configure the LAN. The automatic configuration mode uses DHCP server or Dynamic Link Local Addressing (Automatic IP), as described in Rule 8.6 to obtain the instrument IP address.

### 9.5.1 Recommendation – Default Description for LXI Device

The default description for the LXI Device should be manufacturer name, instrument type, model, and the serial number (e.g., Xyz Oscilloscope 54321D – 123456).

### 9.5.2 Recommendation – Auto-Negotiate Enable/Disable Through Web Page

If the LXI Device implements auto-negotiate enable/disable, then it should be exposed through the web page.

### 9.5.3 Recommendation – Ping Enable/Disable Through Web Page

If the LXI Device implements ping enable/disable, then it should be exposed through the web page.

### 9.5.4 Permission – Other Information on the LAN Configuration Page

Other additional information/IP configuration settings may be added to the IP configuration page (e.g., Domain Name).

### 9.5.5 Permission – Disable Switch for LAN Configuration Page

The IP configuration web interface may be disabled with a non-volatile switch or a key. For example, this switch may be a physical jumper setting or a front panel menu item in the LXI Device.

### 9.5.6 Rule – mDNS Enable/Disable Through Web Page

If the LXI Device implements mDNS enable/disable, then it shall be exposed through the web page.

### **9.5.7 Rule – Reverting Hostname to Factory Default**

Setting the hostname field to the empty string (i.e., a string of length zero, or one consisting entirely of whitespace characters) shall revert the hostname to the factory default value.

### **9.5.8 Rule – Reverting Device Description to Factory Default**

Setting the Device Description field to the empty string (i.e., a string of length zero, or one consisting entirely of whitespace characters) shall revert the Device Description to the factory default.

## 9.6 RULE – Sync Configuration Web Page Contents

For LXI Devices implementing any of the following Extended Functions, the sync configuration web page is required and shall be populated with the information defined in the appropriate Extended Function documents in the section on Web Page Requirements:

LXI Clock Synchronization Extended Function (IEEE 1588)

LXI Event Messages Extended Function

LXI Wired Trigger Bus Extended Function

## 9.7 Deprecated Recommendation – Status Web Page Contents

Deprecated in LXI Version 1.6

## 9.8 RULE – Web Page Password Protection

Any page(s) that allows the user to change the instrument’s settings shall be password protected; user changeable default passwords are acceptable. This applies to the HTTPS connection and the HTTP connection if still supported.

If the LXI Security Extended Function is implemented, the web page password shall be replaced by the credential management required by the LXI Security Extended Function.

### **Observation**

Various guidelines and laws are being considered or have been established that affect password requirements. It is the LXI Vendor responsibility to adhere to relevant guidelines and laws.

### 9.8.1 Revoked Permission – Blank password

Blank passwords are not allowed.

## 9.9 RULE – LXI Logo

All the required web pages for an LXI Device shall contain the LXI Logo (see LXI Consortium Trademark and Logo Usage Guidelines).

## 9.10 Recommendation – LXI Web Interface Example

LXI Device web interfaces should follow the similar look and feel as the *Example Web Pages* in the [LXI Example and Reference Material](#) document.

## 9.11 Recommendation – LXI Device Control Using Web Page

LXI Devices should provide the ability to interact, control, setup and perform troubleshooting on the most common functions through a web interface, without writing a program.



## 9.12 Recommendation – Software/Firmware Upgrade Using Web Interface

As needed, LXI Devices should be able to update software/firmware utilizing the embedded Web interface. Updates should include minor file updates, major software updates, measurement application downloads, or OS changes.

## 9.13 Recommendation – LXI Glossary

LXI Device web interface should support one of the following options to help explain the terminology used in this LXI specifications document:

- *Copy of the glossary from the [LXI Example and Reference Material](#) document*
- *Link to a help file contains the glossary*
- *Link to a help file contains the glossary on the instrument vendor's home page*

## 9.14 RULE – All URLs Beginning With “LXI” Are Reserved by the LXI Consortium

RFC 4248 and 4266 (obsoleted RFC 1738) define the HTTP URL as the following:

```
http://<host>[:<port>]/<path>?<searchpart>
```

Any URL with a <path> that begins with the strings “lxi” or “LXI” or any combination of lowercase and uppercase letters combined to spell LXI shall be reserved for Consortium-defined uses. This includes the directory-like syntax in which the first part of <path> is any combination of lowercase and uppercase letters that spell LXI terminated with a “/”:

```
http://<host>[:<port>]/lxi/<path>?<searchpart>
```

# 10 LAN Discovery and Identification

## 10.2 RULE – LXI API Identification Methods

Devices shall provide the following REST API as defined in the LXI API Extended Function:

URL	HTTP Method	Summary
/lxi/identification	GET	Returns identity information about the device (and connected devices). This is an unsecure API.  Note compliant implementations might not include the Content-Type response header.

### Observation

NOTE Regarding LXI 1.6.1: the rules in LXI 1.6 (and some earlier versions) regarding the LXI Identification have been moved to the general LXI API Extended Function without substantive changes.

This includes LXI 1.6 Rules and Permissions:

- 10.2.1 PERMISSION – HTTP Redirection
- 10.2.2 RULE – Content Type Header
- 10.2.3 RULE – Schema Location Attribute
- 10.2.4 RULE – Connected Device URLs
- 10.2.4.1 RULE – Connected Device XML Identification Document URLs
- 10.2.4.2 RULE – Connected Device XML Identification Document Schema Location Attribute

### Observation

Devices are expected to implement all the RULES in the LXI API Specification that bear on implementing the LXI Identification API. This includes the Common Method Requirements. Special attention should be paid to sections regarding returning HTTP responses indicating that the device is ready for normal operation.

## 10.2.5 RULE – LXI Extended Function Elements

Devices that support LXI Extended Functions shall provide Function elements within the LXIExtendedFunctions element, and a string containing the version number specifying the implementation of that extended function. In addition, some extended functions may provide additional information within their Function element. This allows clients to enumerate the set of extended functions associated with the device.

All relevant XML schemas and examples showing their usage can be found in the LXI Standard GitHub Website located here: <https://lxistandard.github.io/>

## 10.3 RULE – Support mDNS

LXI Devices shall support Multicast DNS (mDNS) as defined by RFC6762 and RFC6763

## **Observation**

LXI Devices, which implement Dynamic Configuration of Link Local Addresses (AutoIP), are useful on a LAN with no central administration (e.g., DHCP server or manual static IP assignment authority). Similarly, Multicast DNS allows devices to perform DNS operations on a local link, even without the presence of an administered DNS server. This is useful for setting up simple LANs, allowing devices and controllers to use meaningful hostnames in a cooperative manner. With the addition of DNS Service Discovery (DNS-SD), it becomes straightforward for clients and servers to advertise, browse, and discover service products (e.g., HTTP servers) on the LAN.

### **10.3.1 RULE – Claiming Hostnames**

LXI Devices shall assign themselves an mDNS hostname and shall automatically resolve mDNS hostname conflicts.

#### **10.3.1.1 RULE – Hostname Conflicts**

If an mDNS hostname conflict occurs, the LXI Device shall assign itself a new hostname and retry until the conflict is resolved. New hostnames shall be generated by appending a number to the end of the hostname. For example, a conflict on “Instr-ABC” would become “Instr-ABC-2” after the first collision, “Instr-ABC-3” on the second, and so on.

### **10.3.2 Recommendation – Default mDNS Hostname**

The default hostname as defined in Section 8.9 should be used as the default mDNS hostname.

### **10.3.3 RULE – Dynamic DNS Update and mDNS Hostname**

LXI Devices that support Dynamic DNS Update shall use the user-configured hostname as the mDNS hostname.

### **10.3.4 RULE – DHCP “Host Name” Option and mDNS Hostname**

Regardless of any value, a DHCP server may return as the DHCP “Host Name” option (option code 12); an LXI Device shall use the user configured or factory default hostname for mDNS hostname registration. (See Section 10.7)

## **Observation**

This rule helps ensure stability since the mDNS hostname should remain unchanged when the device is moved between different networks

## **10.4 RULE – Support mDNS Service Discovery**

LXI Devices shall support Service discovery based on mDNS and DNS as defined by RFC6762 (Multicast mDNS) and RFC6763 (DNS based Service Discovery).

### 10.4.1 RULE – Claiming Service Name

LXI Devices shall assign themselves a service name used to advertise services defined within this standard and shall automatically resolve service name conflicts.

#### **Observation**

Service names are meant to be browse-able and should be as descriptive as possible. Spaces are encouraged to promote readability.

### 10.4.2 RULE – Single Service Instance Name for LXI Defined Services

LXI Devices shall assign themselves a single service name for use in advertising all required and recommended LXI services, as below, and shall resolve service name conflicts. The service instance name is the “instance” portion of a service name as follows:

<instance>. <service>. <domain>

Thus, an HTTP service with an instance name of “Instrument ABC” in the “.local” domain will have “Instrument ABC.\_http.\_tcp.local” as the service name.

#### 10.4.2.1 RULE – User Configurable Service Name

LXI Devices shall allow a user to modify the non-volatile service name via the web interface, truncated to the first 63 bytes of UTF-8. When a user modifies a service name, the LXI Device shall unregister all services and then reregister using the new service name.

#### 10.4.2.2 Recommendation – Default Service Name

LXI Devices should use the recommended default description of section 9.5.1 for their default service name truncated to the first 63 bytes of UTF-8.

#### 10.4.2.3 RULE – Service Name Conflicts

If an mDNS service name conflict occurs, the LXI Device shall assign itself a new service name and retry until the conflict is resolved. New service names shall be generated by appending a number to the end of the service name. For example, a conflict on “Vendor Instrument” would become “Vendor Instrument (2)” after the first collision, “Vendor Instrument (3)” on the second, and so on.

The character setting-off the appended number can be a dash, parenthesis or any other legal character, or no extra character at all.

The following are some examples of valid ways to append the number to the device name:

- *Mydevice1*
- *Mydevice-1*
- *Mydevice(1)*

This applies to both the mDNS Hostname and mDNS service name.

### 10.4.3 Rule - Required Service Advertisements and TXT Record Keys

LXI Devices shall, at a minimum, advertise the following services via mDNS and shall provide the related keys in the TXT records for the service. Please refer to 10.4.3.5 for Permission on TXT Record Keys with default values (NOTE: in this section, the term default is used to refer to the value of a field when it is absent).

Service Type	TXT Record Keys - Required	Description
http (_http._tcp)	txtvers=<version of TXT record">; default "txtvers=1"; current version is 1  path=<path to the root or index page of the server">; default "path=/"	All HTTP servers that a device supports that may be used with a typical web browser
lxi (_lxi._tcp)	txtvers=<version of TXT record">; default "txtvers=1"; current version is 1  Manufacturer=<first element of response to IEEE 488.2 *IDN?>  Model=<second element of response to IEEE 488.2 *IDN?>  SerialNumber=<third element of response to IEEE 488.2 *IDN?>  FirmwareVersion=<fourth element of response to IEEE 488.2 *IDN?>	An LXI service that uses the HTTP protocol for identification and other operations as defined by this standard

**Observation**

The \_http.\_tcp and \_lxi.\_tcp service types should: if the unsecure HTTP service is enabled then it should advertise the port (default 80) where the unsecure HTTP service is configured. If the unsecure HTTP service is not enabled then it should advertise the port where the secure HTTP (HTTPS) service is configured.

Note that the unsecure HTTP service may redirect to the secure HTTP (HTTPS) server (default 443).

**10.4.3.1 RULE – TXT Records Are Required**

The LXI Device shall provide a TXT record for every service instance being advertised. If there are no TXT record entries for a service (see Permission 10.4.3.5), an empty TXT record shall be provided.

**10.4.3.2 RULE – TXT Records Consist of Key/Value Pairs**

TXT records shall consist of key/value pairs of the form “name=value” (without quotes). The value begins after the first ASCII equal sign “=” and continues to the end of the string. The maximum length of a key/value pair is 255 bytes.

**10.4.3.3 RULE – TXT Record Keys Are Case-Insensitive ASCII**

All TXT record keys (names) shall be printable ASCII characters (0x20-0x7E), excluding “=” (0x3D), and shall be case-insensitive.

#### 10.4.3.4 **RULE – TXT Record Values**

TXT record values (data beginning after the ASCII equal sign “=” [0x3D]) in general shall be opaque binary data but may be ASCII or UTF-8 for particular keys.

#### 10.4.3.5 **Permission – TXT Record Key Default Values**

If the value of a TXT record key is equal to the default value for that key, it may be omitted from the TXT record.

#### 10.4.3.6 **RULE – TXT Record Key Order**

For any service that has a defined TXT record key of “txtvers” the “txtvers” key, if present, shall be the first key in the TXT record.

#### **Observation**

The “txtvers” key is recommended by the DNS-SD maintainers for all new protocols to promote compatibility across versions of the protocol. This key must be provided if it has a value other than 1 and, if present, it must be the first key in the TXT record so that clients can easily parse the TXT record.

#### 10.4.3.7 **RULE – LXI Consortium TXT Record Keys**

All TXT record keys beginning with “LXI” or “lxi” are reserved for Consortium-defined usage.

#### 10.4.3.8 **RULE – Vendor Defined TXT Record Keys**

All TXT record keys (names) used with LXI Consortium required or recommended services shall be either keys (names) as defined by this standard or vendor-specific keys. Vendor-specific keys shall end with the vendor’s domain name in accordance with section 6.4 of <http://files.dns-sd.org/draft-cheshire-dnsext-dns-sd.txt>. That is, vendor-defined keys shall be of the form “keyname.company.com=”.

#### 10.4.3.9 **Recommendation – Maximum Length of TXT Record**

TXT records should be no longer than 512 bytes.

#### 10.4.3.10 **Recommendation – Additional Service Advertisements**

If LXI Devices support the following services, they should advertise the services via mDNS, as shown in the table below.

Service Type	TXT Record Keys	Description
scpi-raw (_scpi-raw._tcp)	txtvers=<version of TXT record">; default "txtvers=1"; current version is 1  Manufacturer=<first element of response to IEEE 488.2 *IDN?>  Model=<second element of response to IEEE 488.2 *IDN?>	Raw SCPI (IEEE 488.2) command interpreter

	<p>SerialNumber=&lt;third element of response to IEEE 488.2 *IDN?&gt;</p> <p>FirmwareVersion=&lt;fourth element of response to IEEE 488.2 *IDN?&gt;</p> <p><b>Deprecated in Version 1.6.1</b> Address=&lt;VISA Address&gt;</p> <p>Examples: TCPIP::myHostName.local::5025::SOCKET TCPIP::10.1.1.2::5025::SOCKET</p>	
<p>scpi-telnet (_scpi-telnet._tcp)</p>	<p>Same TXT Record Keys as above except Address should only contain IP address and port number</p> <p><b>Deprecated in Version 1.6.1</b> Address=&lt;IP Address or Hostname&gt;:&lt;port&gt;</p> <p>Example: myHostName.local:5024</p>	<p>Telnet server supporting SCPI (IEEE 488.2) commands</p>

**10.4.3.11 Deprecated RULE – Service Advertisement Order**

**10.4.3.12 Deprecated Recommendation – Additional Service Advertisement Order**

Deprecated in LXI Version 1.6

**Observation – Service Advertisement Order**

In previous versions of this specification rules (10.4.3.11 and 10.4.3.12) specified the order in which service advertisements should be done. These rules have now been removed (deprecated).

RFC 6762 is the definition for mDNS and it states the primary objective of mDNS is to minimize network traffic. For LXI to enforce an order in the advertising of services and conflict resolving them one by one would cause significantly more traffic than advertising all supported services in one packet.

LXI devices must conflict resolve duplicate service names as in Rule 10.4.2.3. The LXI specification doesn't generally tell a device how to accomplish a rule which is what rules 10.4.3.11 and 10.4.3.12 are implying.

Device vendor may advertise all their supported services, one at a time or add all the supported services in a single record. Whichever method they choose they can advertise the services in any order they wish.

### 10.4.3.13 Recommendation – Description Service Advertisements and TXT Record Keys

\*IDN responses should be consistent with Rule 10.4.3 descriptions to ease machine readability.

## 10.5 RULE – mDNS and DNS-SD Enabled by Default

Both mDNS and DNS-SD shall be enabled by default on LXI Devices.

### 10.5.1 RULE – mDNS and DNS-SD Enabled by LAN Configuration Initialize (LCI)

When the LCI reset mechanism is activated, it shall enable mDNS and DNS-SD.

### 10.5.2 Rule – Provide way to Disable mDNS and DNS-SD

Devices shall provide a way to enable and disable mDNS and DNS-SD.

#### **Observation**

Devices shall provide a way to disable mDNS (e.g., via a web interface), but mDNS shall be re-enabled when the LCI is activated, as mDNS and DNS-SD are useful in locating instruments on the LAN. The principal reason for disabling mDNS and DNS-SD is to suppress service announcement traffic which some IT organizations consider to be a security risk.

## 10.6 RULE – mDNS Name Resolution

LXI Devices shall use mDNS for name resolution of hostnames in the ".local." domain. Reverse lookups of addresses in the 169.254/16 subnet (Dynamic Link-Local Addresses) shall be resolved via mDNS.

#### **Observation**

In addition to claiming and responding to queries for its hostname via mDNS, a device must also resolve hostnames for outgoing connections (e.g., LXI Event communication) via mDNS. mDNS hostnames should always be specified as Fully Qualified Domain Names (FQDNs) that is with the ".local." domain.

## 10.7 RULE – Nonvolatile Hostnames and Service Names

To promote stability, if a hostname conflict occurs and the LXI Device chooses a new hostname, the device shall save the new hostname in nonvolatile storage for use the next time the device is powered on. Similarly, if a service name conflict occurs and the LXI Device chooses a new service name, it shall save the new service name in nonvolatile storage for use the next time the device is powered on.

#### **Observation**

The device should save the original (desired) hostname or service name along with any new hostname or service name acquired through conflict resolution. If, subsequently, the new hostname or service name conflict at startup, the device should revert to use of the desired hostname or service name. Otherwise, a “Device-1-2” or “Device-1-3” could occur.



### **10.7.1 RULE – Hostname and Service Name Revert to Default**

When the LCI mechanism is activated, the hostname and the service name shall revert to the last user-configured values, if available, or factory defaults otherwise.

## **10.8 RULE – Link Changes**

When a network “link change” occurs (e.g., an Ethernet cable is plugged in), the LXI Device shall verify that its hostname and service name are unique and shall re-register its services.

# 11 Documentation

## 11.1 RULE – Full Documentation on IVI Interface

For each LXI Device, the manufacturer shall provide the documentation on the IVI driver, which is required in the Conformance Requirements section of the IVI 3.1 Driver Architecture Specification.

## 11.2 RULE – Registration of the IVI Driver

The IVI driver shall be registered at the IVI Foundation website and be listed on the IVI Foundation driver registration database.

## 11.3 Recommendation – Documentation on LXI Device Web Page

The documentation should be provided through the LXI Device’s webpage or accessible from the vendor website.

### *Observation*

A sufficiently powerful device could provide an html version of the documentation through its own web interface.